

# Load control strategies for Hydrogen Fuelled IC Engines

**Roger Sierens, Sebastian Verhelst**

Ghent University  
Department of Flow, Heat and Combustion Mechanics  
Sint-Pietersnieuwstraat 41, BE-9000 Gent  
Tel.: +32/9/264 33 07, Fax: +32/9/264 35 90  
[Roger.Sierens@UGent.be](mailto:Roger.Sierens@UGent.be)

## Abstract

Spark ignition engines can be converted to hydrogen by mounting a hydrogen fuel system and gas injectors (PFI port fuel injection). Due to the lower volumetric energy density of hydrogen a PFI hydrogen engine has about 15% power deficit compared to a gasoline engine.

There are different options for H<sub>2</sub>ICEs (PFI) to obtain power outputs similar to or exceeding the power output of an equivalent, naturally aspirated, gasoline engine, without excessive tailpipe NO<sub>x</sub> emissions. A first option is to stay lean of the 'threshold equivalence ratio', the air to fuel equivalence ratio below which NO<sub>x</sub> emissions rise exponentially, and make up for the power loss caused by the lean mixtures through supercharging. A second option is supercharging at stoichiometric mixtures, or in practice at slightly rich of stoichiometric so that a small amount of unburned hydrogen is present in the exhaust which is an effective reducing agent for NO<sub>x</sub>, using a three way catalyst.

The second option, running at stoichiometric, is not always possible without occurrence of abnormal combustion phenomena. Using exhaust gas recirculation (EGR) is a means to allow reliable stoichiometric operation. Furthermore, varying the EGR rate can be used to control the power output (as opposed to throttling) which benefits the engine efficiency, and NO<sub>x</sub> emissions decrease because of the thermal inertia of the EGR gases.

Results are shown of the different load control strategies for two single cylinder PFI hydrogen engines tested at the Ghent university.

## Introduction

One of the advantages of using hydrogen in spark-ignition engines is the possibility of using wide open throttle (WOT) operation throughout most of the load range. This is beneficial for the engine efficiency. Also hydrogen fuelled engines can run from stoichiometric to very lean.

It is clear that there are a number of operating strategies for hydrogen engines, which depend on the power demand, and are related to the limitation of NO<sub>x</sub> emissions. At low loads, the load can be controlled by the equivalence ratio (qualitative approach), as combustion temperatures then stay below the NO<sub>x</sub> formation temperature. The engine is then run under wide open throttle conditions, so that pumping losses are negligible which benefits the brake thermal efficiency. For medium to high power demand, using this approach leads to high NO<sub>x</sub> emissions, once the equivalence ratio becomes richer than some threshold. For most engines this threshold is around  $\lambda \sim 2$ . The high NO<sub>x</sub> emissions for mixtures richer than this threshold are difficult to reduce with after treatment, as the mixture is still lean and thus the exhaust is oxygen-rich.

A solution is to switch to a strategy with a fixed, stoichiometric, equivalence ratio and the use of exhaust gas recirculation (EGR).

The EGR principle is that a part of the exhaust gases is fed back to the intake of the engine. Compared with the lean burn strategy, the excess air is replaced by the recycled exhaust gases. Power is now regulated by varying the amount of EGR while maintaining a stoichiometric mixture. The specific heat capacity (cp) of the exhaust gases is higher than that of air, so the total heat capacity of the cylinder mixture is higher. As a result the combustion temperature will decrease so NO<sub>x</sub> production will also decrease.

Super- or turbocharging is a way to increase the power output to gasoline levels or even higher. In this study supercharging is used instead of turbocharging. Of course, turbocharging will increase the efficiency of the engine but it is much more difficult to handle. By supercharging the boost pressure can be chosen independent of the power output of the engine [1-2].

Hydrogen port injection is at the moment the most common hydrogen mixture formation strategy. Only the installation of hydrogen injectors in the inlet manifold are necessary to modify a gasoline or natural gas engine to a hydrogen engine (of course with adaptation of the electronic control system for ignition and injection timing). In the early stage gas carburetors were used. This is even a more simple strategy and works very well if one is not interested in the power output of the engine (lean mixture to avoid backfire) [3-4].

Much research is going on direct injection of hydrogen in the combustion chamber of the engine [5-7]. Direct injection is certainly the best strategy to avoid combustion problems (as backfire) and to increase the power output of the engine. Research is going on early and late DI (homogenous or stratified), multiple DI (before and after spark) and on jet-guided, well-guided or air-guided injection concepts. Direct injection has a future for high efficiency, high powered engines.

The literature on hydrogen fuelled internal combustion engines is surprisingly extensive and the publications started already in the 1930's. Recent work is on the formation techniques (port and direct injection), combustion anomalies (backfire, pre-ignition and knock), load control strategies (power output versus NO<sub>x</sub> trade-off) and most recently on hybrid strategies (PFI + DI, lean burn + stoichiometric operation using EGR) to obtain power output equivalent to gasoline engines with extremely low emissions levels [8-9].

The infrastructure for hydrogen or the availability of hydrogen fueling stations versus a hydrogen vehicle is like the chicken and egg problem. But hydrogen has the great advantage of the possibility to run bi-fuel and/or dual fuel. The authors are convinced that a bi-fuel (gasoline or hydrogen) [10-11] and dual fuel (80% natural gas with 20% hydrogen) [12-13] are the immediate solutions towards a hydrogen driven transport economy.

## Test engines

Two single cylinder engines are used in this study:

### 1. CFR engine:

A single cylinder CFR engine (612cc, fixed speed of 600 rpm, variable compression ratio), is equipped with a sequential PFI injector (and MoTeC control unit), exhaust gas recirculation and a three way catalyst. The engine set-up is shown in Fig. 1, a full description of the test rig is given in ref. [14].

### 2. Audi engine:

A single cylinder Audi engine (400cc) is coupled with a DC motor. The operating speed is regulated between 1500 and 4500 rpm and the compression ratio is set to 11.

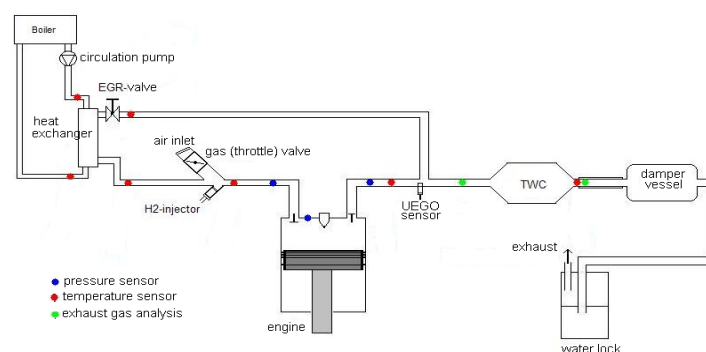
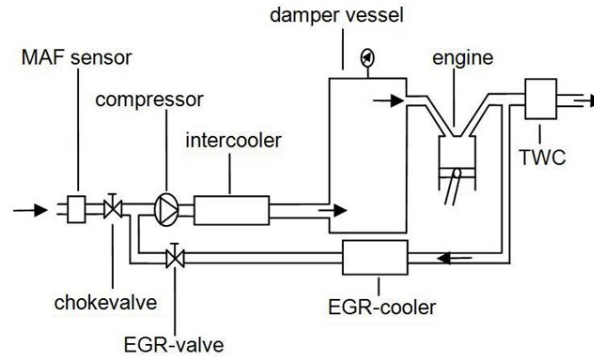

Figure 1. CFR engine test rig

Two Teleflex GFI gas injectors are used for PFI and can withstand an injection pressure up to 5 barg which is necessary to inject at supercharged operation. A Bronkhorst Hi-Tec H<sub>2</sub> flow meter (F-113AC-HDD-55V) measures the hydrogen-flow.

The experimental setup is equipped with a compressor (Busch MN 1102), feeded with an inverter, so supercharging up to 2 barg can be used. Exhaust gas can be recirculated to the intake of the compressor after it is cooled by an additional EGR-cooler. A MoteC M4 Pro ECU is installed to control the ignition and injection parameters.

The engine-set-up of the Audi engine is shown in fig 2.



**Figure 2. Audi engine bench layout**

To measure the non-stationary flow of these single cylinder engine a flow meter is installed before a damper vessel of the inlet system. In-cylinder and exhaust pressures are measured with piezoelectric pressure transducers, the inlet pressure with a piezoresistive transducer. The lambda value is measured with a Bosch wide band sensor and digitized with a digital air/fuel ratio meter calibrated for hydrogen. The emissions (H<sub>2</sub>, O<sub>2</sub>, CO, CO<sub>2</sub>, NO<sub>x</sub>) are detected by a gas analyzer from Mairhak.

A safety circuit measures the build-up H<sub>2</sub> in the damper vessel. A safety compressor circulates a part of the gasses in the damper vessel and a Buveco H<sub>2</sub>-sensor (ST600EX) measures the amount of H<sub>2</sub> in the gasses. When there is too much H<sub>2</sub>, the hydrogen supply stops. Another safety H<sub>2</sub>-sensor is installed on top of the engine with a tapered roof to collect all the gasses.

## Results

### CFR engine

Tests on the CFR engine are carried out for lean hydrogen-air mixtures and for stoichiometric hydrogen-air mixtures with the addition of a variable amount of EGR. A comparison is made of the two strategies: the influence of EGR and lean combustion on the indicated power output, the indicated efficiency, the NO<sub>x</sub> emissions and the conversion efficiency of a three way catalyst (TWC) is examined.

The normalized indicated power and the indicated efficiency for lean burn and EGR strategies are plotted in Fig. 3 as a function of the hydrogen consumption (the two strategies are best compared for the same input energy). In the figure the measured conditions are given with the values of the hydrogen fuel consumption (QH<sub>2</sub>) as discrete points (no linear scale of the abscissa), as well as the corresponding λ-values (for the lean burn strategy) and the corresponding EGR rates (for the EGR strategy). The higher the fuel rate is, the higher the load condition of the engine. For the lean burn strategy this corresponds with a richer mixture (but still on the lean side of λ = 1), for the EGR strategy it corresponds with a lower EGR rate.

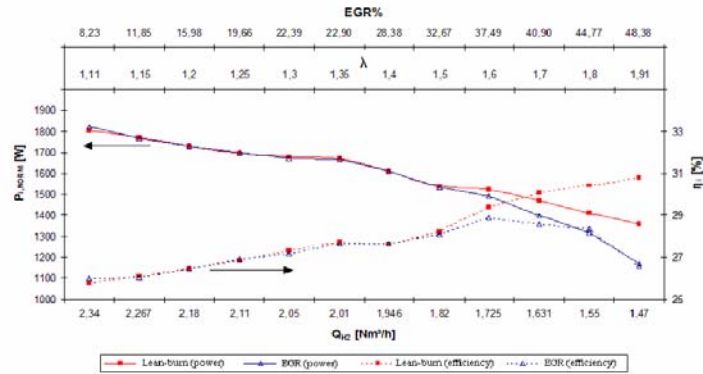

**Figure 3. Indicated power and indicated efficiency for lean burn and EGR strategies**

The engine conditions in Fig. 3 are for the fixed speed of 600 rpm, a compression ratio of 9.5:1 and MBT ignition timing. It is to be pointed out that due to the valve timing (no valve overlap) there exists already a significant internal exhaust gas recirculation. The mentioned values of the EGR rate in the figure are only for the external exhaust gas recirculation.

There is an expected increase in power output as a function of the fuel (hydrogen) rate (nearly linear for the lean burn strategy). There is also an expected decrease in indicated efficiency as a function of increasing load (increasing fuel rate) as the mixture becomes more stoichiometric for the lean burn strategy (decrease of indicated efficiency by decreasing  $\lambda$  value). For the EGR strategy the indicated efficiency drops at low load conditions. At the same time the COV values (coefficient of variation in indicated mean effective pressure) increase drastically, indicating unstable combustion and the practical limit of the use of high EGR rates.

The measurements learn that except for the lower load conditions (low hydrogen flow, higher  $\lambda$  - values and higher EGR rates) the power output and the indicated efficiency are nearly the same for the lean burn strategy and for the EGR strategy. In the literature [15-16] experimental results have been reported where the indicated efficiency with lean burn is higher than the indicated efficiency with EGR.

In previous tests (different set-up of the test rig) the EGR was cooled and the condensate evacuated, resulting in a higher efficiency of the EGR strategy. Then the condensate discharger was removed (but still cooling the EGR). Efficiency dropped but was still slightly higher compared to the lean burn strategy.

In the tests presented here (Fig. 3) the EGR was not cooled anymore, giving an inlet temperature of the mixture, for both strategies, between 45 and 50°C. Therefore, a similar power output and indicated efficiency is found in both strategies as volumetric efficiencies are very similar (except at low load conditions with a too high EGR rate).

Raw NO<sub>x</sub> emissions (cylinder out, untreated) versus air/fuel equivalence ratio have a maximum value around an air-fuel ratio  $\lambda$  of 1.2 (high combustion temperature and excess of air). At stoichiometric and even at lean conditions (till  $\lambda = 2$ ; trade-off for NO<sub>x</sub> ≤ 100 ppm) the NO<sub>x</sub> concentration in the exhaust gases is too high, and special measures (after treatment by catalyst) are necessary. For mid to high loads the use of a TWC was examined (with the strategy of stoichiometric mixtures diluted with EGR).

To increase the conversion efficiency of the TWC for the NO<sub>x</sub> emissions, tests were carried out for slightly rich conditions of the mixture ( $\lambda \sim 0.95$ ), as also used in some H<sub>2</sub> demonstration engines [10-17]. Table 1 gives the NO<sub>x</sub> and H<sub>2</sub> emissions before and after the TWC and the NO<sub>x</sub> conversion efficiency as a function of the fuel flow. This is done, and is only possible, following the EGR strategy (otherwise backfire occurs). Figure 4 gives the NO<sub>x</sub> emissions and the conversion efficiency of the TWC. In these tests the conversion efficiency is high, and is higher for high load conditions (low EGR rate). Here, the excess hydrogen in the exhaust gases is used for the reduction of the NO<sub>x</sub>, and is

consumed in the TWC. Figure 4 and Table 1 learn that for high loads (high temperatures) about 1 to 1.5 vol % H<sub>2</sub> is needed in the exhaust gases to obtain conversion efficiencies of more than 80%.

For lower load conditions the temperature of the exhaust gases is lower where higher amounts of H<sub>2</sub> are necessary to obtain a sufficient conversion efficiency. Table 1 shows that for decreasing fuel flow (decreasing load) the NO<sub>x</sub> emissions before the TWC decrease accordingly, but the NO<sub>x</sub> emissions after the TWC remain nearly the same due to the decrease in the conversion efficiency (from 84 % to 66 %). It is to be noted that the raw NO<sub>x</sub> emissions for a rich mixture ( $\lambda \sim 0.95$ ) are lower than for the stoichiometric EGR strategy (NO<sub>x</sub> production is maximum around  $\lambda \sim 1.2$ ). The indicated efficiency decreases with richer mixtures as part of the fuel (H<sub>2</sub>) is not burnt in the combustion chamber. H<sub>2</sub> emissions out of the TWC should be as low as possible (for efficiency and safety).

	Q <sub>H<sub>2</sub></sub>	EGR	NO <sub>x</sub> before	NO <sub>x</sub> after	$\eta$ TWC	H <sub>2</sub> before	H <sub>2</sub> after
Test	Nm <sup>3</sup> /h	%	ppm	ppm	%	%	%
1	2.318	12.77	1679	275	84	2.17	0.58
2	2.110	20.73	1508	235	84	1.58	0.34
3	2.015	24.70	1120	196	83	1.63	0.55
4	1.960	29.30	1065	240	78	1.90	0
5	1.869	31.99	638	220	66	2.0	0

Table 1: NO<sub>x</sub> and H<sub>2</sub> emissions before and after the TWC (EGR strategy,  $\lambda \sim 0.95$ )

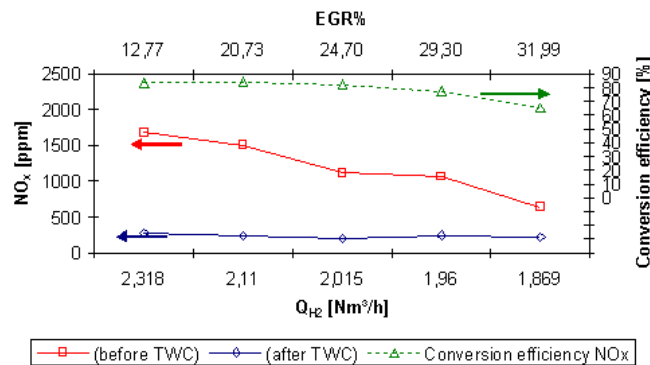

Figure 4: NO<sub>x</sub> emissions before and after TWC and conversion efficiency (EGR strategy,  $\lambda \sim 0.95$ )

## Audi engine

### 1 Initial tests

First, some experiments at atmospheric conditions are done to set a baseline for the supercharging experiments. A threshold equivalence ratio, defined as the equivalence ratio where NO<sub>x</sub> emissions reach 100ppm, of  $\lambda \sim 2$  was found for this engine.

The maximum brake mean effective pressure (bmep) at stoichiometric is only 6.5 bar. However, the volumetric efficiency for this engine is very low, due primarily to the air mass flow meter and extensive piping before and after the damper vessel (see Fig. 2). If the volumetric efficiency is defined as the ratio of the measured air and hydrogen flow to the flow that would fill the swept volume at atmospheric conditions, values of (only) about 70% are found.

Then, initial experiments on the supercharged single cylinder engine were aimed at determining any power benefit. All measurements reported in this section are with a supercharging pressure of 0.5 barg (measured in the damper vessel). The test bench was initially equipped with a Zepher turbo compressor (blower), limited to 0.5 barg supercharging pressure. Figure 5 shows the resulting maximum power output as a function of engine speed. The net power output for the supercharging

experiments (accounting for the power needed to drive the air blower) is compared to the power output for the atmospheric experiments.

Supercharging results in a net power increase of about 40%. This is somewhat less than what could be expected from the supercharging pressure (given that the intercooler is over dimensioned), but is easily explained as stoichiometric operation was no longer possible when supercharging. The air to fuel equivalence ratio  $\lambda$  is now limited to 1.3 to 1.4, because of backfire or pre-ignition. This essentially means that the power increase cannot be used because of the resulting high  $\text{NO}_x$  emissions in an oxygen-rich environment. Recycling part of the exhaust gases is a means to displace some of the intake air and enrich the mixture, so experiments with EGR were done to determine the possibility of running stoichiometric at supercharged conditions.

Figure 5 shows the (net) maximum power output as a function of engine speed when exhaust gas recirculation is used while supercharging. Stoichiometric operation is now possible without backfire or pre-ignition events, through increasing both the injected fuel quantity and the EGR rate. The high heat capacity of the recycled exhaust gases (with a high water vapor content) is the reason why the fueling rate can be increased without abnormal combustion phenomena. As a result, not only is stoichiometric operation now possible with efficient  $\text{NO}_x$  after treatment, but furthermore the power output can be seen to increase slightly. This results in a net power increase of almost 50%. The maximum brake mean effective pressure now is 9.4 bar (at 3500 rpm). As mentioned higher, this is a research engine with low volumetric efficiency, so this should not be compared to the bmep of a production gasoline engine. Comparing to (atmospheric) measurements on this engine on methane [18], a power increase of about 20% is found, extrapolating this gives an estimate of the power increase compared to atmospheric gasoline operation of roughly 10%.

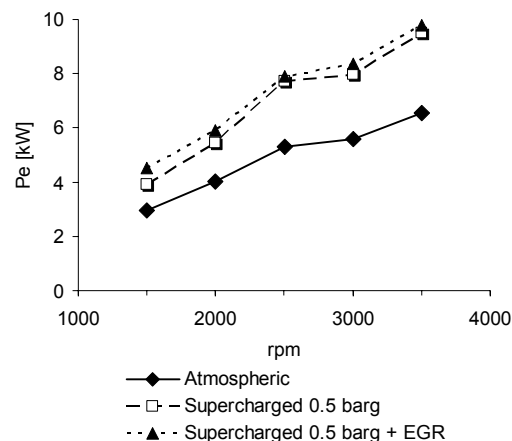

**Figure 5. Brake power as a function of engine speed. WOT, atmospheric operation at stoichiometric; supercharged operation at backfire/pre-ignition limited equivalence ratio ( $\lambda=1.3-1.4$ ); and supercharged operation with EGR at stoichiometric ( $\lambda=1$ ).**

## 2 Supercharging lean mixtures

After the first initial tests a new Busch claw compressor is installed to obtain higher supercharging pressures (up to 1.5 barg). In [19] tests are described at an engine speed of 2000 rpm, WOT and charging pressures from 0 barg (atmospheric) to 1 barg and this for the lean burn strategy and for the stoichiometric + EGR strategy.

These tests are now extended for the whole speed range of the engine and for supercharged pressure higher than 1 bar.

As mentioned before all measurements are done at wide open throttle (WOT) and with the aim to keep oxides of nitrogen ( $\text{NO}_x$ ), limited to 100 ppm. This is strongly dependant on the air-fuel ratio (the threshold equivalence ratio is around  $\lambda \simeq 2$ ) ( $\phi \simeq 0.5$ ), also dependant on the load condition (supercharging pressure) and slightly on the engine and the engine speed.

The measurements are done in the speed range 1500 to 3000 rpm with steps of 250 rpm and charging pressures from atmospheric to 1.5 barg. The results are shown in Fig. 6 as the normalized brake power versus engine speed. The brake torque of the engine crank shaft is measured and corrected by the required power to drive the volumetric compressor (supercharger). And the corrected effective power is adjusted by the atmospheric temperature and pressure for normalized power output.

Fig. 6 shows the maximum normalized power for a supercharging pressure of 1.2 barg. That for higher charging pressures the power is not further increased is due to two factors. First, additional supercharging needs higher compressor power (increase in necessary compression power is more than linear). Second, to stay under the NO<sub>x</sub> limit of 100 ppm, the mixture has to be leaner by increasing supercharging pressure. From atmospheric to a charge pressure of 1.2 bar, all measurements are done with an air-fuel ratio  $\lambda$  of 2 to 2.05. From 1.3 barg the air-fuel ratio has to set leaner to  $\lambda = 2.1$  à 2.3 (and the leaner the mixture, the lower the energy density and the lower the power output).

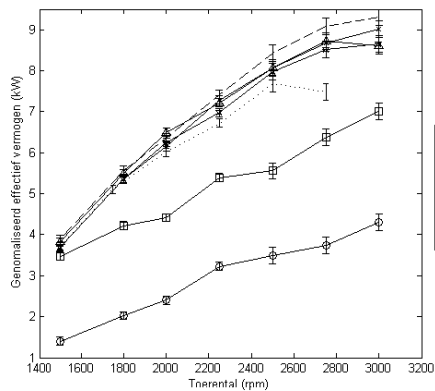

Figure 6.: Normalized brake power

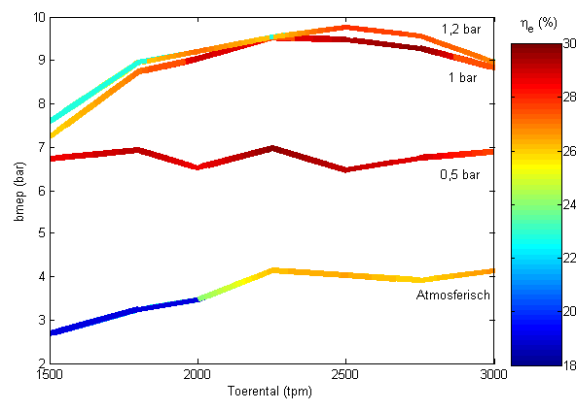

Figure 7.: Net brake mean effective pressure and efficiency

Fig. 7 shows the net brake mean effective pressure (bmep) and the effective efficiency as a function of engine speed and at different charging pressures. As shown in Fig. 6 the highest power output, thus the highest bmep, is for 1.2 barg (with a maximum value of 9.76 bar at 2500 rpm).

All measurements in Fig. 7 are with an air-fuel ratio 2 à 2.05. So no influences of the air-fuel ratio on the efficiency (normally the leaner, the higher efficiencies, see tests on CFR engine).

The lean mixture tests are done also with the TWC, but this has nearly no conversion efficiency of the NO<sub>x</sub>, because of the lean condition of the mixture ( $\lambda \simeq 2$ ). But this is not a real problem because the strategy of lean mixtures is to work without after treatment catalysts.

The power output or the brake mean effective pressure (bmep) at atmospheric condition is very low. This is due to the low volumetric efficiency for this engine (about 70%) (see before). Also friction losses are inherently higher for a single cylinder engine.

### 3 Supercharging stoichiometric mixtures + EGR

These tests are done also with (nearly) WOT (see further) and stoichiometric mixtures. In fact the air-fuel ratio was just rich ( $\lambda \simeq 0.97$ ) to have hydrogen as a reduced agent in the TWC (see tests on the CFR engine)

The tests are done for atmospheric and charging pressures of 0.5, 0.7 and 1 barg and engine speeds of 1800, 2250 and 3000 rpm.

Exhaust gas recirculation (EGR) is used to obtain NO<sub>x</sub> values under the threshold limit of 100 ppm. The EGR rate is given following the formula:

$$EGR\% = \dot{m}_{EGR} / (\dot{m}_{EGR} + \dot{m}_{air} + \dot{m}_{H_2})$$

The normalized brake power is shown in Fig. 8 for these tests.

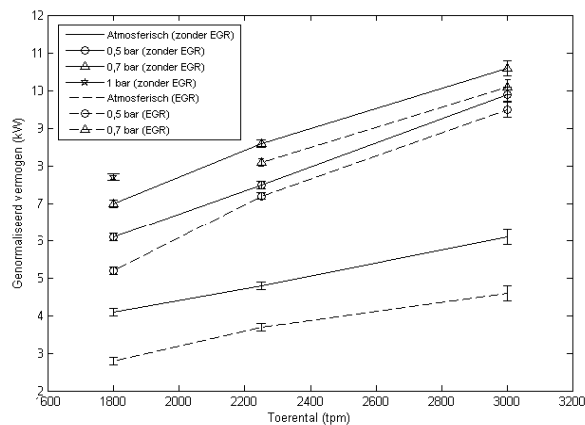

Figure 8.: Normalized brake power

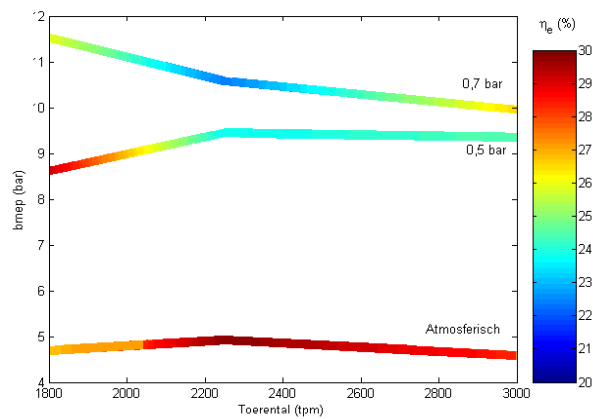

Figure 9.: Net brake mean effective pressure and efficiency

To avoid knock and backfire the ignition timing has to be decreased, even after TDC.

The EGR rate changes drastically for the different load conditions, from 30 to 40% at atmospheric and around 10% for 0.7 barg.

The reason for this is the temperature of the exhaust gases and the conversion degree of the TWC.

The exhaust temperature increases with higher charging pressures. Above a temperature of 500°C the conversion efficiency of the TWC is up to 95%. Without supercharging (atmospheric) the exhaust temperature for this engine stays too low, resulting in a low conversion efficiency. This is the reason a high rate of EGR is necessary for the atmospheric condition.

Referring to the tests on the CFR engine (Fig. 3) there is a different approach. The tests on the CFR engine are done to regulate the power output by changing the EGR rate (thus high loads need lower EGR rates). The main focus for the Audi tests is to stay under the 100 ppm NO<sub>x</sub> emissions level.

Supercharging is limited to 0.7 barg (and 1 barg only at 1800 rpm) to withstand too high pressures and temperatures in the combustion chamber (mechanical constraint). With stoichiometric and supercharging higher power output is possible than lean supercharging ( $P_e \text{ norm} \approx 10.6 \text{ kW}$  and  $\text{bmep} \approx 11.5 \text{ bar}$ ).

Fig. 9 shows the net brake mean effective pressure and the efficiency.

The efficiencies are in general lower than for supercharged lean mixtures. Only for atmospheric conditions (mid range) high efficiencies (up to 30%) are obtained. The main reason is the ignition timing which is set very late and after TDC (to avoid backfire). At atmospheric condition, with high EGR rate, this was not necessary. A second reason is that to ensure the recirculation flow of the exhaust gases, the inlet pipe had to be throttled ( $\pm 0.1 \text{ barg}$ ). This causes additional pumping losses (no real WOT strategy).

## Conclusions

Different load control strategies are discussed for port fuel injected (PFI) hydrogen engines.

In a CFR engine a comparison is made between lean burn strategy and stoichiometric operation + EGR. With both strategies load can be regulated with the same efficiencies (only at low load the EGR strategy gives lower efficiencies, due to an excessive rate of recirculated exhaust gases).

The strategy is simple, the richer the mixture (on the lean side) or the less EGR, the higher the power output. But power output is less than for a gasoline version of the engine. And NO<sub>x</sub> emissions are too high. Even with the installation of a TWC. The conversion efficiency of the TWC is far too low for the lean mixtures (in the mid to high load range of the tests). For the stoichiometric + EGR strategy (in fact  $\lambda \simeq 0.95$  à 0.97, so that the excess of hydrogen act as a reduced agent in the TWC) although a high conversion efficiency of the TWC), the NO<sub>x</sub> emissions are still higher than the threshold value of 100 ppm. Increasing the EGR rate can help, but will decrease further the power output.

In the CFR engine the same strategies are executed but now with supercharging (to obtain higher power output than for a gasoline engine) and to obtain NO<sub>x</sub> emissions lower than 100 ppm.

All the presented results obtain a NO<sub>x</sub> emission level of maximum 100 ppm. For the lean burn strategy the highest power output is for a supercharging pressures of 1.2 barg and efficiencies up to 30% (for supercharging pressures 0.5 to 1 barg).

For the supercharged stoichiometric + EGR strategy even higher power output is obtained (bmep of 11.5 bar) but with a penalty in efficiency (ignition timing after TDC to avoid backfire).

Only at atmospheric, stoichiometric + EGR (high EGR rate, thus low load condition) also an efficiency of 30% is obtained.

## Acknowledgement

.....

## References

- [1]. Natkin R.J., Tang X., Boyer B., Oltmans B., Denlinger A., Heffel J.W. 'Hydrogen IC engine boosting performance and NO<sub>x</sub> study'. SAE technical paper nr 2003-01-0631, 2003.
- [2]. Berckmüller M., Rottengruber H., Eder A., Brehm N., Elsässer G., Müller-Alander G., Schwarz C. 'Potentials of a charged SI-hydrogen engine'. SAE technical paper nr 2003-01-3210, 2003.
- [3]. Sierens R. 'Installation and first experimental results of a hydrogen fuelled engine, Proceedings, 9<sup>th</sup> World Hydrogen Energy Conference, pages 31-40 (Addendum), 1992.
- [4]. Sierens R. and Verhelst S. 'Comparison between a carburetted and a port injected hydrogen fuelled single cylinder engine'. Proceedings, EAEC European Automotive Congress, Bratislava, paper SAITS 01009, 2001.
- [5]. Bartunek B., Mumford D., Welch A. 'Development of H<sub>2</sub> Direct Injection Technology for high efficiency/high BMEP engines.' 1<sup>st</sup> Int. Symposium on Hydrogen Internal Combustion Engines, Graz, 28-29 September 2006, pp 155-163.
- [6]. Rottengruber H., Berckmüller M., Elsässer G., Brehm N., Schwarz C. 'A high-efficient combustion concept for direct injection hydrogen internal combustion engine'. 15th World Hydrogen Energy Conference, paper nr 28J-01, Yokohama, Japan, 2004.
- [7]. Wallner T., Nande A.M., Naber J.D. 'Study of Basic Injection Configurations using a Direct-Injection Hydrogen Research Engine'. SAE technical paper nr 2009-01-1418, 2009.
- [8]. Verhelst S., Verstraeten S., Sierens R. 'A critical review of experimental research on hydrogen fueled SI engines'. SAE technical paper nr 2006-01-0430, 2006. Also in SAE 2006 Transactions, Journal of Engines, pp264-274, 2007.
- [9]. Nande A. M., Szwaja S., Naber J. D. 'Impact of EGR on Combustion Processes in a Hydrogen Fueled SI Engine'. SAE paper nr. 2008-01-1039, 2008.
- [10]. Berger E., Bock C., Fischer H., Gruber M., Kiesgen G., Rottengruber H. 'The new BMW 12-cylinder hydrogen engine as clean efficient and powerful vehicle powertrain.' Fisita paper nr F2006P114, Yokohama 2006.
- [11]. Saito T., Matsushita M., Mitsugi H., Ueda T. 'Development of hydrogen rotary engine with dual-fuel system.' Fisita paper nr F2006P200, Yokohama 2006.

- [12]. Sierens, R. Comparative tests on a S.I. engine fuelled with natural gas or hydrogen, Proceedings, ASME Wintermeeting Houston '93 - ASME/ICE Engine Symposium at the Energy-Sources Technology Conference, paper n° 93-ICE-15, 1993.
- [13]. Sierens R., Rosseel E. 'Variable Composition Hydrogen/Natural Gas Mixtures for Increased Engine Efficiency and Decreased Emissions'. Journal of Engineering for gas turbines and power, Transactions of the ASME, January 2000; Vol. 122, p. 135-140.
- [14]. Verhelst S., Sierens R. 'Combustion strategies and NO<sub>x</sub> emissions for hydrogen fuelled IC engines'. FISITA, paper nr. F2006.P092, Yokohama 2006.
- [15]. Heffel J. W. 'NO<sub>x</sub> emission reduction in a hydrogen fuelled internal combustion engine at 3000 rpm using exhaust gas recirculation' International Journal of Hydrogen Energy, vol 28, pp. 1285-1292, 2003
- [16]. Heffel J. W. 'NO<sub>x</sub> emission and performance data for a hydrogen fuelled internal combustion engine at 1500 rpm using exhaust gas recirculation' International Journal of Hydrogen Energy, vol 28, pp. 901-908, 2003.
- [17]. Prümm W. 'Hydrogen engines for city buses.' 1<sup>st</sup> Int. Symposium on Hydrogen Internal Combustion Engines, Graz, 28-29 September 2006, pp 1-11
- [18]. Verstraeten S., Sierens R., Verhelst S. 'A high speed single cylinder hydrogen fueled internal combustion engine'. Proceedings Fisita World Automotive Student Congress, Barcelona, 2004.
- [19]. Verhelst S., Maesschalck P., Rombaut N., Sierens R. 'Increasing the power output of hydrogen internal combustion engines by means of supercharging and exhaust gas recirculation'. Nr nog invullen