

The use of a DMT to monitor the stability of the slopes of a clay exploitation pit in the Boom Clay in Belgium

Herman Peiffer

Ghent University, Zwijnaarde, Belgium. E-mail: herman.peiffer@ugent.be

ABSTRACT: *In Belgium the Boom Clay is a well know overconsolidated clay formation. This Tertiary clay, with a same geological origin as the London Clay, is used for the fabrication of bricks, roofing tiles, expanded clay,.....*

In the article is described how the DMT can be used to evaluate the stability of slopes, to determine the risk of instability and how the cause of the failure directly could be related to the results of the DMT-measurement. The results of the tests before the period of instability, during the period of instability and after stabilization are discussed. The K_D -value is a representative value to judge the risk of instability.

1 INTRODUCTION

In Kruibeke (Flanders) in the period 1963 – 2010 a pit was excavated in the Boom Clay till a depth of about 30 meters. The clay was used for the fabrication of expanded clay granulates.

In 2010, the exploitation of this pit stopped because the borders of the concession were reached.

One year later, in 2011 a first (limited) instability of the slope of this pit occurred (sliding).

Apparently, it became clear that more stability problems could be expected.

In 2012 and 2013, new (limited) slidings occurred.

In the beginning of 2014 it was decided to setup an extensive monitoring program in order to evaluate the risk of further instability of the slopes, site investigation was carried out (DMT). Besides the monitoring of the settlements and the pore water pressures in the environment, DMT-tests were carried out on a regular basis.

In the consecutive DMT-measurements one can clearly see an evolution towards instability. After an important failure (sliding) in one zone in June 2014 (an area of 100 m by 50 m was affected), remediation works were done in the destabilized zone (October – November 2014).

After stabilization, DMT-measurements were done in January 2015, in order to investigate the evolution of the stress state of the soil in the potential sliding surfaces after stabilization.

In the article is described how the DMT can be used to evaluate the stability of slopes, to determine

the risk of instability and how the effect of instability and remediation directly could be related to the results of the DMT-measurement.

The results of the tests before the period of instability, during the period of instability and after stabilization are discussed.

2 SOIL PROFILE AND LAYOUT OF THE SITE

2.1 Geology

Based on the geological investigations and data map, the upper layer consists out of a sandy silt (quaternary deposit). Under this layer the tertiary overconsolidated Boom Clay can be found. This can be seen also on the I_D -diagram as presented below.

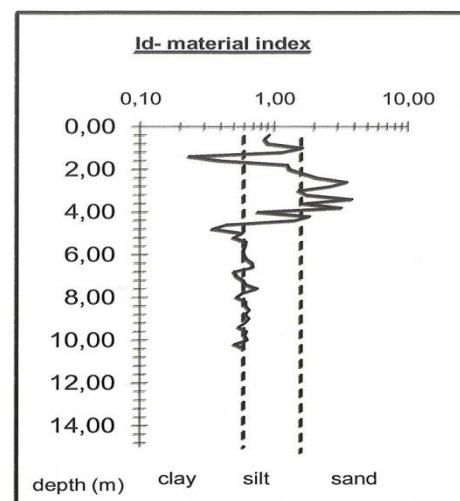

Fig. 1. I_D (DMT1).

2.2 Groundwater

The phreatic water level is at a depth of about 1.5 m (before remediation). The thickness of the clay at the bottom of the pit is about 10 m. This thickness is sufficient in order to resist the upward artesian water pressures.

2.3. Overview of the site and test program

In the figures 2. (photo view) and 3. (map) an overview of the site and the DMT-tests is presented.



Fig. 2. – photo view of the site

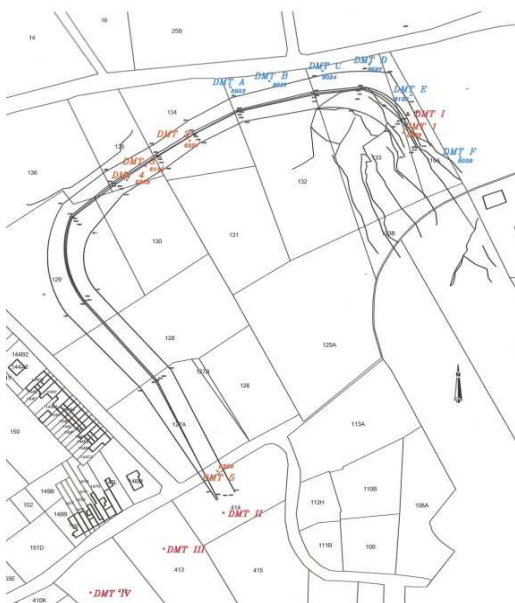

Fig. 3. – map of the site

Until now, three campaigns were organized :

- January 2014 – DMT 1 to 5 (before sliding)
- July 2014 – DMT A to F (after sliding)
- January 2015 – DMT I to IV (after stabilising)

The results of these campaigns are discussed.

3 THE DMT AS A TOOL FOR THE DETECTION OF SLIP SURFACES

3.1 DMT- K_D -method

The principle of the DMT- K_D -method for the detection of slip surfaces can be shown as follows. (Marchetti, 1997).

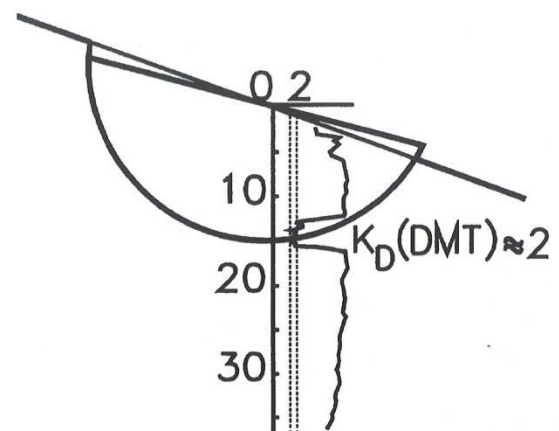

Fig. 4. Principle of the DMT- K_D -method

In many OC clay landslides, the sequence of sliding, remoulding and reconsolidation, leaves the clay in the slip zone in a normally consolidated (NC) or nearly NC state, with loss of structure, ageing or cementation effects.

Based on field data from different clay sites in various geographical areas correlations could be established (G. Totani et al., 1997).

In genuinely NC clays (no structure, ageing or cementation) the horizontal stress index K_D from the DMT is approximately equal to 2, while K_D values in OC clays are considerably higher (for the Boom Clay about 8).

Therefore it is known that, if an OC clay slope contains clay layers with $K_D \approx 2$, these layers are highly likely to be part of a slip surface (active or quiescent).

The DMT- K_D -method method consists on identifying zones of NC-clay in a slope, using $K_D \approx 2$ as the identifier of the NC zones.

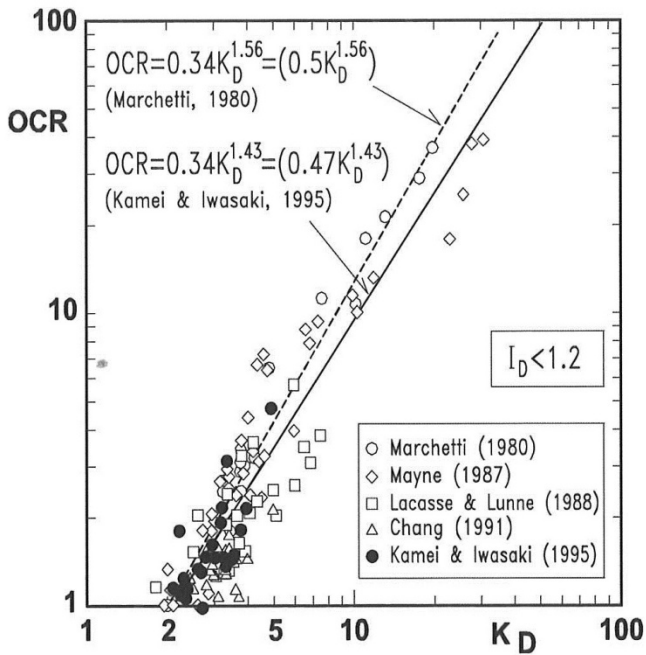

Fig. 5. Correlation KD – OCR for cohesive soils (after Kamei & Iwasaki, 1995)

4 FIRST SLIDINGS

4.1 Period 2011 and 2012

The first instability occurred in 2011. The size of the sliding was limited. No DMT-measurements were done at that moment.

In the second half of 2013 a more important slide occurred in the neighborhood of point 5 on figure 2. The number 5 refers to DMT 5 executed in the beginning of 2014 at a distance of 5 m from the top of the slope.

In the figure 6 a photo of the slide is presented.



Fig. 6. Photo of the unstable zone after sliding

In the figure 7 the K_D -profile of DMT 5 is given (about 3 months after the sliding). The sliding occurred in the quaternary layer until a depth of about 1.5 m in the Boom Clay.

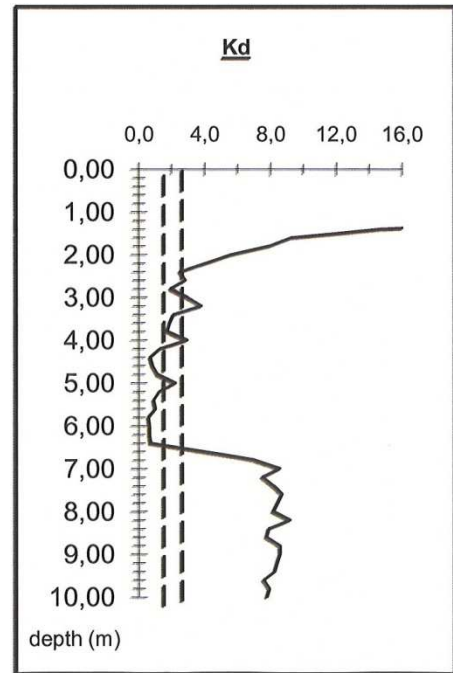

Fig. 7. K_D -profile for DMT 5

5 MORE PRONOUNCED INSTABILITY OF THE SLOPE (2014)

5.1 Instability problems in 2014 (period June-July)

As discussed in 4.1., after the more pronounced sliding in 2013, a monitoring program was elaborated for different points at the top of the slope around the pit. Besides topographic surveys and the measurement of the phreatic water level, DMT-tests were carried out.

In this article the evolution of K_D is discussed only for the two points DMT 1 and DMT 2, because the sliding occurred in this zone.

In the first series of DMT-tests (January 2014), 5 tests were carried out (DMT 1 to DMT 5).

In June 2014 an important sliding occurred (area of about 100 m x 50 m) between DMT 1 and DMT 2

The extent of the affected zone can be seen on the figures 7 and 8. Two profiles are presented in the figures 9. and 10.



Fig. 7. Sliding mass (June 2014)

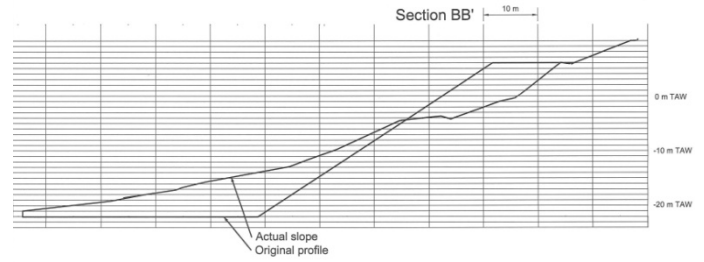

Fig. 10. Section BB' (fig. 8).

5.2 Measurements before and after the sliding

After the sliding DMT-measurements were executed in the immediate neighborhood of the previous DMT tests. It concerns the tests DMT A to DMT E.

The results are presented in the figures 11 for DMT1/DMTE and 12 for DMT2/DMTA.

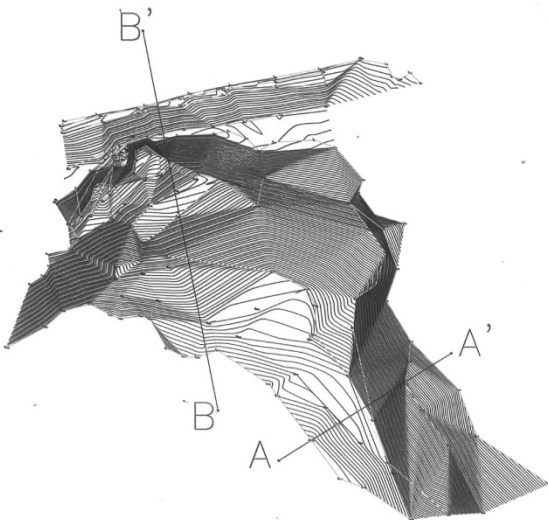
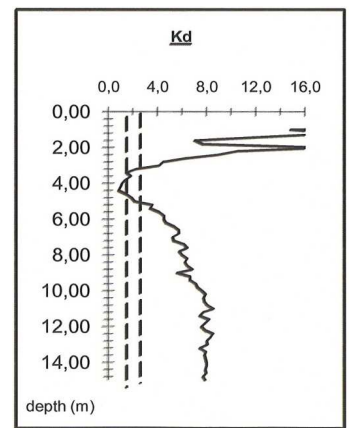
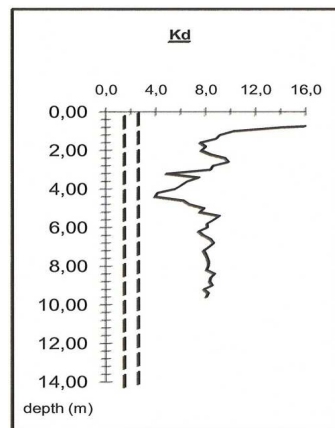

Fig. 8. 3D-print of the NE-corner



(a) (b)
Fig. 11 – K_D before (a) and after (b) sliding (DMT1/DMTE)

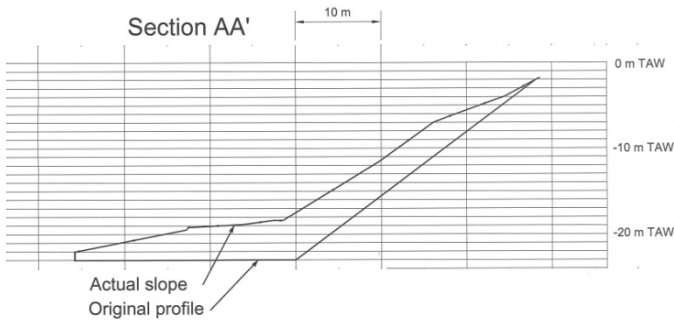

Fig. 9. Section AA' (fig. 8.)

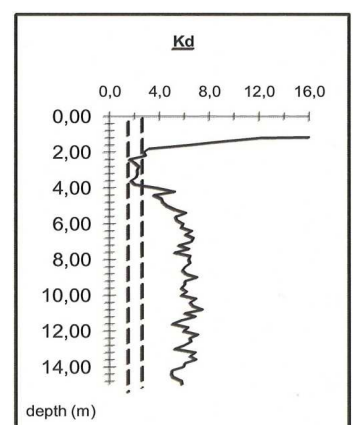
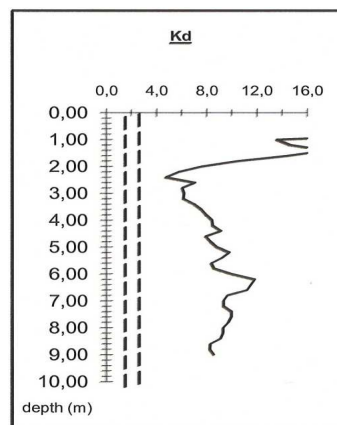

Fig. 12 – K_D before (a) and after (b) sliding (DMT2/DMTA)

In the figures 11 and 12 one can clearly see the effect of the instability on the value of K_D in the upper quaternary layer and the top of the Boom Clay.

It is also important to notice that the K_D -values in the upper meters of the Boom Clay decrease from about 8 to 6.

5.3 Stability analysis

Further investigation and additional calculations showed the importance of the groundwater pressures on the horizontal equilibrium.

Additional CPT-tests and laboratory tests were executed in order to make a detailed stability analysis. Based on an analytic and numerical analysis (PLAXIS-calculation) it was possible to prove clearly the cause of the instability and to design an appropriate improvement of the horizontal stability.

The figure 13 presents the calculated critical horizontal disequilibrium due to the presence of the groundwater.

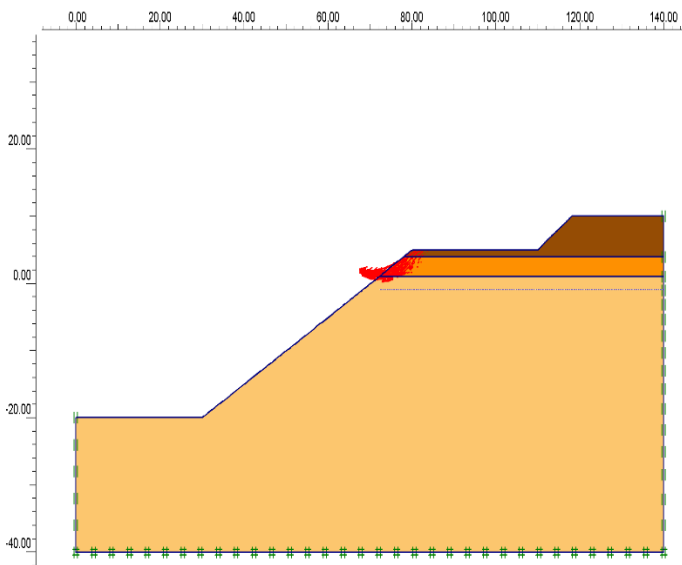

Fig. 13 – PLAXIS-analysis

The analysis resulted in a design where a deep drain has to be installed at a depth of 5 m., as shown in the figures 14 and 15. This drain was installed at the beginning of November 2015. The red line in figure 15 is the position of the drain in plan view.

After the installation of this drain, there was an immediate effect on the depth of the groundwater. The original depth of 1,5 m increased to a depth of about 4.5 m. The safety of the slope stability increased from 0,9 to 1.31.



Fig. 14. Installation of the deep drainage.



Fig. 15. Position of the drain in plan view (red line)

6 DMT-TEST AFTER INSTALLATION OF THE DRAIN

In January 2015 a first series of tests was carried out after the installation of the drain and the execution of works to smoothen the slope. Four tests were carried out. In this article only the result of DMTI (in the immediate neighborhood of DMT1 is presented).

The K_D -profile is presented on figure 16. Compared with figure 11, one can see that there is still a smaller value of K_D in the upper meters of the Boom Clay. The K_D -values in the more sandy layers seem to be increased after installation of the drain.

Although the distance between DMT1 and DMTI is limited (about 2 m), for sure an improvement of the K_D -values could be expected. Further investigation,

in neighbor points and in the future, after definitive remediation of the slope, has to confirm this result.

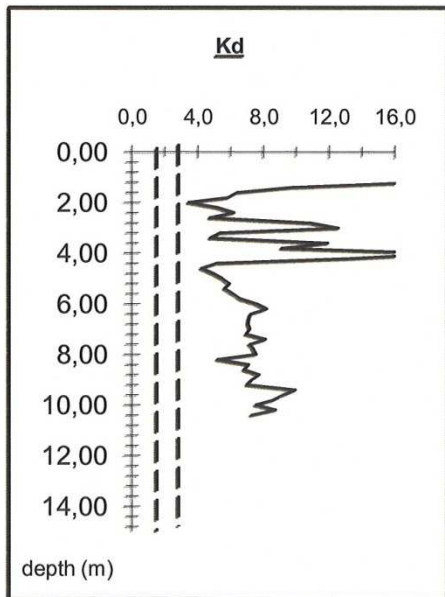

Fig. 16. K_D -profile after installation drain and remediation works

7 CONCLUSIONS

A method has been illustrated for the monitoring of slip surfaces in overconsolidated soil layers, based on the measurement of the DMT- K_D -values.

Instability of the slopes corresponds with K_D -values lower than 2.

There is a pronounced change in K_D -values before and after the sliding in the zone around the sliding surface.

It appeared that the K_D -value of the undisturbed overconsolidated clay immediately beneath the sliding surface decreases, in this investigation from about 8 to about 6.

The K_D -value in the upper more sandy overconsolidated layer, increased again but irregularly after the installation of a deep drainage.

Because it is possible to measure the effect of a sliding on the soil conditions with a DMT-test, and als to detect the position of a slip surface, DMT-testing can give an important added value to the measurements with the inclinometer, who is capable of measuring the movement of a slope.

8 REFERENCES

- D'Elia, B. Esu, F., Marchetti, S. and Totani, G. (1996) "In situ DMT testing and observations in landslide areas in overconsolidated clays", Proc. 7th ISL
- Esu, F. and Calabresi G. (1969) "Slope stability in an overconsolidated clay", Proc. 6th ICSMFE 2 : 255-263.
- Kamei, T. & Iwasaki, K. (1995) "Evaluation of undrained shear strength of cohesive soils using a flat dilatometer.", Soils and Foundations 35 (2): 111-116
- Lacasse, S. and Lunne, T (1988). "Calibration of dilatometer correlations", Proc. ISOPT-1 1:348-359
- Marchetti, S. (1980) "In situ tests by flat dilatometer", ASCE Jnl G.E. (106) (GT3): 299-321
- Marchetti, S., Monaco, P., Totani, G. and Calabrese, M. (2001) "The Flat Dilatometer Test (DMT) in soil investigations – A Report by the ISSMGE Committee TC16, International Conference On In Situ Measurement of Soil Properties, Bali (Indonesia)
- Peiffer, H. (1997), "Interpretatie en aanpassing van de dilatometerproef, uitgebreid tot de beoordeling van de spanningstoestand naast schroefpalen" Doctoral Thesis, Ghent University
- Peiffer, H. (2015), "Studierapport stabiliteit kleigroeve te Kruibeke", Antwerpen
- Rampello, S. (1989) "Effetti del rigonfiamento sul comportamento meccanico di argile fortemente sovraconsolidate" Doctoral Thesis, University of Rome.
- Totani, G., Calabrese, M., Marchetti, S. and Monaco, P. (1997) "Use of in-situ flat dilatometer (DMT) for ground characterization in the stability analysis of slopes", XV ICSMFE Hamburg, vol 1 : 607-610