

Reducing switching losses through MOSFET - IGBT combination

Alex Van den Bossche¹, Vencislav C. Valchev², Angel St. Marinov³

Abstract – This paper introduces a configuration aimed at switching losses reduction through a power leg constructed by combining a MOSFET and an IGBT. The combined use of these different switches leads to the turn-on losses reduction through the use of the faster freewheeling diode of the IGBT, and the turn-off losses reduction through use of the MOSFET's lower losses because of the lack of tailing current, typical for IGBT's. The introduced leg structure can be used to build single phase – full bridge inverters or three phase inverters. The proposed leg is realized, experimented and validated.

Keywords – Switching losses, Losses reduction, Conventional inverters.

I. INTRODUCTION

In many applications where PWM controlled inverters are used, conventional means of reducing losses, such as soft switching [] and resonance circuits [] are inapplicable. Furthermore, in some of those applications such as motor control and distributed generation, where a significant part of the load (the motor in the first case and the grid in the second) is inductance, losses from the freewheeling diode reverse recovery are a major part of the switching losses. This means that realizing the desired scheme with MOSFETs can introduce significant turn-on losses due to the poor quality of the MOSFET's freewheeling body diodes and their high reverse recovery time. Using IGBTs on the other hand has disadvantage of increased turn-off switching losses due to the IGBT's tailing current. This paper introduces a configuration aimed at losses reduction through a power leg constructed by combining a MOSFET and an IGBT. The introduced leg structure can be used to build single phase –full bridge inverters or three phase inverters.

II. PROPOSED MOSFET-IGBT POWER LEG

The introduced topology's main advantage versus the conventional MOSFET or IGBT topologies is the reduction of the total losses in the switches. When only MOSFET are used there are larger switching losses during the on stage due to the high reverse recovery of the MOSFET's body diode. IGBTs on the other hand, have smaller turn on losses due to the absence of a parasitic body diode and the opportunity of using a better freewheeling diode, but

however they have larger losses during the off stage because of tail currents. By putting a MOSFET and IGBT in one leg the losses can be reduced combining the better properties of the two switches.

The proposed topology is shown on Fig.1. It is a full bridge inverter consisting of combined IGBT&MOSFET legs.

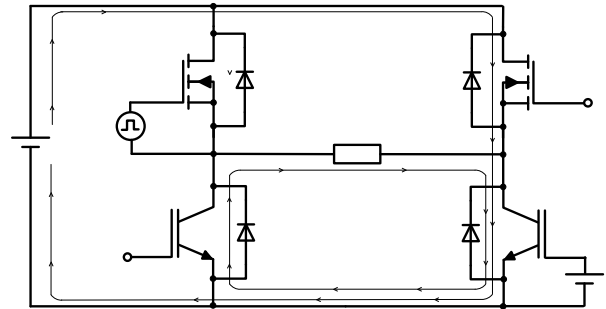

Fig.1 IGBT and MOSFET Bridge circuit.

In the proposed scheme the MOSFETs – S1, S3 and their parasitic body diodes – D1, D2 are placed in the upper half of each leg and the IGBTs – S2, S4 and their incorporated diodes are placed in the lower half of the legs. The load Z connected to the output terminals is of resistive-inductive nature.

The presented in the paper analysis is made only for the shown full bridge inverter. The same assumptions and conclusions however can also be made for a three-phase conventional bridge inverter. The analysis of this topology is made only for one half period of the output inverted voltage assuming that the same can be implied for the other half. During the positive half of the output voltage – S4 is constantly 'on' and is conducting the main current I_1 , while a PWM control sequence is applied on S1 in order to regulate the output. When S1 is turned off, the diodes D2 and D4 provide an alternative path for the stored energy in the inductive part of the load. After 'turning off' the S1, the diodes D2 and D4 conduct some time and then they do not stop conducting simultaneously, conversely it takes a finite

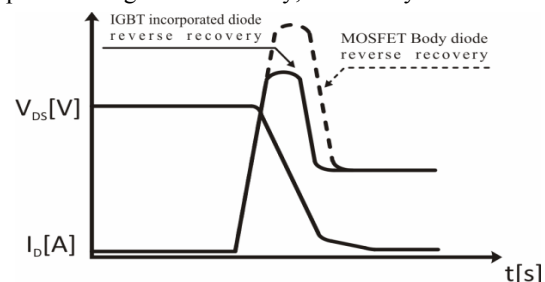

Fig. 2 Switch-on losses of pure MOSFET leg compared with IGBT,MOSFET leg switch-on losses.

amount of time that a diode requires in order to restore its reverse blocking capability. During that time the current I_2

¹Alex Van den Bossche is with Ghent University, Belgium.

²Vencislav C. Valchev - Technical University – Varna, Varna

"Studentska" №1, Bulgaria, E-mail: vencivalchev@hotmail.com

³Angel Marinov is with Technical University – Varna, Varna

"Studentska" №1, Bulgaria, E-mail: igdrazil@abv.bg

flows through the transistor S1, thus increasing considerably its turn-on switching losses. The loss increase in the switch-on period due to the freewheeling diode depends on the diode's qualities, in particular its reverse recovery time. In the proposed topology D₂ and D₄ are diodes incorporated in the IGBT's package (or fast recovery discrete diodes), therefore the reverse recovery time will be much shorter in comparison with MOSFET body diodes. The MOSFET body diodes are of parasitic nature and have poor qualities. The recovery time of the incorporated IGBT diodes is tuned to the switching time of the IGBT itself and therefore it is considerably shorter, as it is shown in Fig.2. The switches S₁ and S₃ are the modulating switches that operate on high frequency – therefore getting most of the switching losses, but S₁ and S₃ are MOSFET's which do not have tail currents, thus the turn-off switching losses are reduced compared to a topology build entirely on IGBTs – Fig. 3.

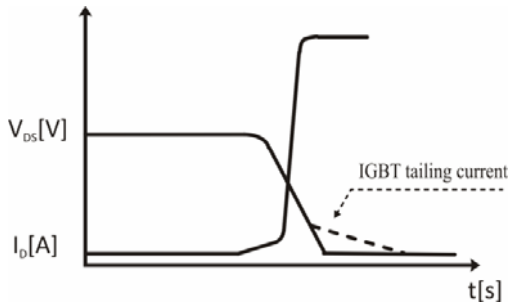

Fig. 3 Switch-off losses of an IGBT leg compared with a combined MOSFET & IGBT leg.

The total loss reduction of the MOSFET & IGBT bridge is shown at Fig.4 using the typical waveforms. The location of the IGBTs and the MOSFETs can be switched, placing the MOSFETs on the bottom and IGBTs on the top. The condition to be kept is: the MOSFETs are the modulating switches and the IGBTs are the conducting ones.

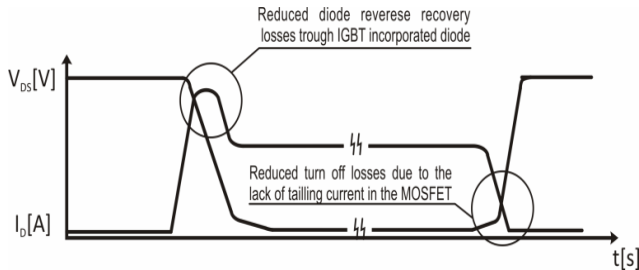

Fig. 4 Switching losses reduction of an IGBT & MOSFET leg.

III. ANALYTICAL COMPARISON USING MANUFACTURER DATA

In case of an IGBT and a MOSFET with identical 'switch on' times (which can be considered possible because of the switching-on processes of an IGBT and a MOSFET are almost similar), the difference between the switching losses of a pure MOSFET and a pure IGBT topology will be mainly concentrated in the added reverse recovery current of the freewheeling diode. The switched on losses due to the diode reverse recovery can be described by (1), [1]:

$$P_{rr}(I_{on}) \approx f \cdot V_{dc} \cdot \left[Q_{rr} + \left(\frac{I_{on}}{2 \cdot di/dt} + t_{rr} \right) \cdot I_{on} \right] \quad (1)$$

where:

P_{rr} : power dissipation included by the reverse recovery charge of the diode.

Q_{rr} : reverse recovery charge of the diode.

t_{rr} : reverse recovery time.

I_{on} : output current at turn-on.

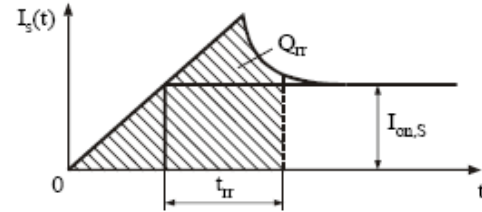

Fig.5 Current of the switch during the turn-on transition

The Figure 5 describes the equation (1). For simplicity, we assume that the diode voltage drops after t_{rr} .

First, in order to compare losses in the turn-on transient due to the reverse recovery time of a MOSFET body diode and of a IGBT incorporated diode, the data sheets characteristics of one MOSFET and one IGBT are used. The components are in the same power and price class. They are chosen so that they have similar turn-on times and similar conduction losses. The parameters of the two transistors are listed in Table 1.

Table: 1
Proposed combined MOSFET-IGBT power leg.

IGBT		MOSFET	
IRGP4062D	Price:6,38€	STW26NM60	Price:8,94€
$V_{CE}=600V, I_C=24A, V_{CE}=1,65V$		$V_{DS}=600V, I_D=19A, R_{DS}=0,135\Omega$	
IGBT switching characteristics		MOSFET switching characteristics	
$t_{d(on)}=40ns$	$I_c=24A, V_{cc}=400V, R_G=10\Omega, T_j=175^\circ C$	$t_{d(on)}=35ns$	$I_D=13A, V_{DD}=300V, R_G=4,7\Omega, T_j=150^\circ C$
$t_r=24ns$		$t_r=22ns$	
$t_{d(off)}=125ns$		$t_{d(off)}=14ns$	
$t_f=39ns$		$t_f=20ns$	
IGBT incorporated diode switching characteristics		MOSFET incorporated diode switching characteristics	
$t_{rr}=89ns$	$I_F=24A, T_j=175^\circ C$	$t_{rr}=560ns$	$I_F=26A, T_j=150^\circ C$
$Q_{rr}=4,3\mu C$		$Q_{rr}=9\mu C$	

Although values for the different parameters of the IGBT and the MOSFET are given for different testing conditions (Table 1), comparison between the parameters can give a first view of the results where one or another of the components is used. The comparison is carried out using the data for the MOSFET's and the IGBT's diodes and applying respectively their reverse recovery time t_{rr} and

their reverse recovery charge Q_{rr} in (1). It is clear that using IGBT's incorporated diode will reduce the reverse recovery losses almost twice compared to the MOSFET's body diode. This shows that when using combination of a MOSFET and an IGBT, where the IGBT's diode is used to freewheel, the turn-on losses can be reduced significantly.

Depending on the use of MOSFET or IGBT, the turn-off switching losses differ because of the presence of tailing current. Tailing current is one of IGBT's disadvantages. It increases the turn-off transition and thus increasing the losses during turn-off. The losses during turn-off for both MOSFETs and IGBTs can be presented by the time needed to switch, t_{off} , and the corresponding values of the voltage and current (2):

$$P_{off} = V_{dc} \cdot I_{on} \cdot t_{off} \quad (2)$$

Tailing current is usually included in the turn-off time for the IGBT provided in the datasheet. Comparing the turn-off times shown in Table 1 it is clear that the MOSFET needs several times lesser time switch-off than the IGBT. This shows that the MOSFET&IGBT combination inverter will have less turn-off losses than the pure IGBT topology, because in the combined scheme, switching losses are concentrated in the MOSFET.

IV. EXPERIMENTAL VERIFICATIONS

A. Conditions of the carried out experiments.

For simplicity, the carried out experiments are realized only for one combined leg MOSFET&IGBT. All results however can be applied as well as for circuits composed of such a leg, such as single phase full bridge inverters or three-phase inverters as long as the IGBT is used for conducting the load current and the MOSFET is used to modulate the current.

Figure 6 shows the tested topology of MOSFET&IGBT. The leg is composed of one MOSFET switch – S1 and its body diode D1 and one IGBT switch - S2 and its incorporated diode D2. The load is a series connected inductor –L and resistor –R. When analyzing advantages of the MOSFET and IGBT combination, the load is connected between the common point of S1 and S2 and the negative supply point. In this scheme S1 is switched on and off and S2 is kept closed – Fig.6. In this situation when S1 is switched-on current I_1 flows from the positive point of the supply, through S1, through the load and to the negative supply point. When S1 is switched-off the IGBT's incorporated diode D2 provides a path for the stored energy in L, thus conducting the current I_2 . By measuring the voltage drop on S1 and the current from the supply – I_1 , the reduction of turn-on losses because of the use of the “good” IGBT incorporated diode and the lack of tail current on turn-off in the MOSFET can be observed.

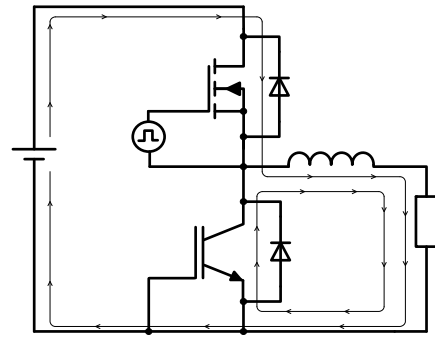

Fig. 6 MOSFET and IGBT leg circuit to prove the loss reduction of the proposed MOSFET&IGBT leg.

The structure that is shown Fig.7 is used to test turn-on losses with low quality MOSFET body diode such as in pure MOSFET topology, and turn-off losses with tailing current – such as in pure IGBT topology. The difference in the testing Set-up of Fig.7 compared with Fig.6 is that the R-L load is connected to the plus instead of the minus, and that the MOSFET – S1 is kept closed and the IGBT – S2 is switched on and off. In that way, the current I_1 flows in the following circuit: the supply's plus, the load, the IGBT – S2 and the supply's minus. The current I_2 corresponding to the stored energy in L freewheels through the body diode of the MOSFET – D1.

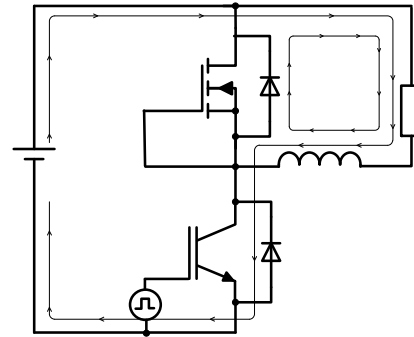

Fig. 7 MOSFET and IGBT leg circuit to show the disadvantages of the conventional approach.

Using the above circuits and measuring the voltage drop across the IGBT and the supply current, verification results are obtained to compare the losses of: first – the proposed combined MOSFET&IGBT; second – the pure IGBT and third – a pure MOSFET topologies. The turn-on results of the IGBT – S2 can provide comparison between the combined use of IGBT and MOSFET and pure MOSFET topologies – considering that the turn-on of an IGBT is equivalent to that of a MOSFET. The turn-off results of the IGBT – S2 can provide comparison between the combined use of IGBT and MOSFET and pure IGBT topologies – considering that the turn-on loss of diode D1 is negligible.

B. Experimental results.

The shown experimental results in Fig.:8 to Fig.:11 are obtained according to the above described conditions. Values for the applied DC source voltage, used load, transistors, and frequency of the control voltage are listed in the Table:2.

Table: 2
Experimented set up for MOSFET&IGBT power leg, 50 kHz

Components	value
R	30Ω
L	$8,5mH$
$S1,D1(MOSFET)$	$STW26NM60$
$S2,D2(IGBT)$	$IRGP4062D$

Figure 8 shows the current waveform of the combined MOSFET&IGBT leg, while Fig.9 shows the current waveform of the pure MOSFET topology. Comparing the two waveforms shows that the current peak on turn-on, due to the reverse recovery of the freewheeling diodes, in the pure MOSFET leg is significant, while in the MOSFET&IGBT leg it is almost not present. In terms of losses this means a significant reduction in the MOSFET&IGBT leg compared to the MOSFET leg.

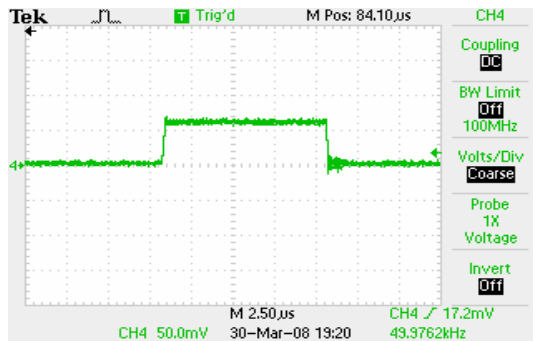

Fig. 8 Current waveform in MOSFET&IGBT combined leg.

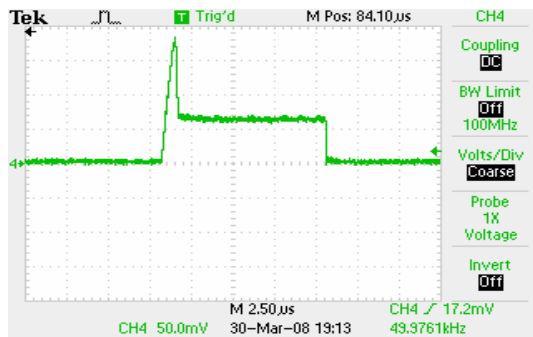

Fig.9 Current waveform in MOSFET leg.

Figure10 shows the turn-off current waveform of the combined IGBT&MOSFET leg, while Fig.:11 shows the turn-off current waveform of a pure IGBT circuit. By comparing the two it can be seen that the pure IGBT leg has tail current, unlike the MOSFET&IGBT leg in which regardless of the significant ripple tail current is not present. In terms of power losses this means that the MOSFET&IGBT leg have lower losses then the pure IGBT leg.

V. CONCLUSION

This paper presents a configuration aimed at switching losses reduction through a power leg constructed by combining a MOSFET and an IGBT.

PCIM'03, Germany, 05.2003, pp. 423-427.

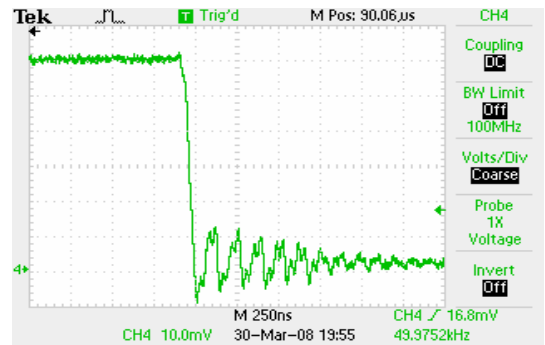

Fig. 10 Turn-off current waveform MOSFET&IGBT in leg.

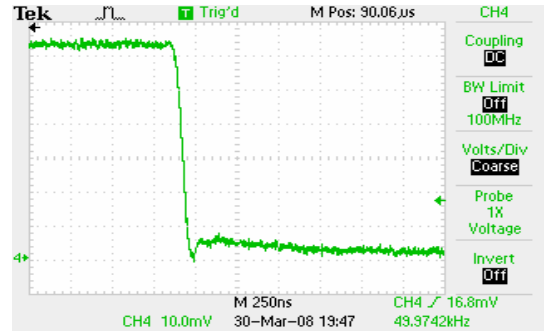

Fig.11 Turn-off current waveform IGBT in leg.

The advantage of this combination of two different switches leads to the turn-on losses reduction through the use of the faster freewheeling diode of the IGBT, and the turn-off losses reduction through use of the MOSFET's lower losses because of the lack of tailing current, typical for IGBT's. The introduced leg structure can be used to build single phase – full bridge invertors or three phase invertors.

ACKNOWLEDGEMENT

This paper was developed in the frames of a PhD project, sponsored by TU Varna, 2008.

REFERENCES

- [1] Smith K. et. al., 'A Comparison of Voltage-Mode Soft-Switching Methods for PWM Converters', IEEE Transactions on Power Electronics, vol.12, No2, March 1997, pp.376-386.
- [2] Zhang J. M., et. Al., 'Comparison Study of Phase-Shifted Full Bridge ZVS Converters', 2004, 35th Annual IEEE PESC, Aachen, Germany, 2004, cd-rom.
- [3] Vencislav Valchev et al., 'Design Considerations and Loss Analysis of ZVS Boost Converter,' IEE Electric Power Applications, vol.148, No1, January, 2001, pp.29-33.
- [4] Chang-Sun Kim, et. al., 'Alternately Zero Voltage Switched Forward, Flyback Multi Resonant Converter Topology', IEEE IES, Sevilla, November 5-8, 2002, cd-rom.
- [5] Farrington R, F. Lee, M. Jovanovic, 'Constant frequency zero-voltage multi-resonant converters: topologies, analysis and experiments', IEEE PESC, 1991, pp. 33-40.
- [7] Gradinarov N., N. Hinov, D. Arnaudov, "Analysis and Design of Resonant Inverters with Improved Output Characteristics, Zero-Current Switching",