

# Recommendations on the use of echocardiography in adult hypertension: a report from the European Association of Cardiovascular Imaging (EACVI) and the American Society of Echocardiography (ASE)<sup>†</sup>

Thomas H. Marwick<sup>1</sup>, Thierry C. Gillebert<sup>2</sup>, Gerard Aurigemma<sup>3</sup>, Julio Chirinos<sup>4</sup>, Genevieve Derumeaux<sup>5</sup>, Maurizio Galderisi<sup>6</sup>, John Gottdiener<sup>7</sup>, Brian Haluska<sup>8</sup>, Elizabeth Ofili<sup>9</sup>, Patrick Segers<sup>2</sup>, Roxy Senior<sup>10,11</sup>, Robyn J. Tapp<sup>12</sup>, and Jose L. Zamorano<sup>13\*</sup>

<sup>1</sup>Menzies Research Institute Tasmania, Hobart, Australia; <sup>2</sup>University of Ghent, Ghent, Belgium; <sup>3</sup>University of Massachusetts, Worcester, MA, USA; <sup>4</sup>University of Pennsylvania, Philadelphia, PA, USA; <sup>5</sup>Université Claude Bernard Lyon, Villeurbanne, France; <sup>6</sup>Federico II University Hospital, Naples, Italy; <sup>7</sup>University of Maryland, College Park, MD, USA; <sup>8</sup>University of Queensland, Brisbane, Australia; <sup>9</sup>Moorhouse University, Washington, DC, USA; <sup>10</sup>Biomedical Research Unit, Imperial College, London, UK; <sup>11</sup>Royal Brompton Hospital, London, UK; <sup>12</sup>University of Melbourne, Melbourne, Australia; and <sup>13</sup>University Hospital Ramón y Cajal, Carretera de Colmenar Km 9.100, Madrid 28034, Spain

Received 1 March 2015; accepted after revision 7 March 2015

Hypertension remains a major contributor to the global burden of disease. The measurement of blood pressure continues to have pitfalls related to both physiological aspects and acute variation. As the left ventricle (LV) remains one of the main target organs of hypertension, and echocardiographic measures of structure and function carry prognostic information in this setting, the development of a consensus position on the use of echocardiography in this setting is important. Recent developments in the assessment of LV hypertrophy and LV systolic and diastolic function have prompted the preparation of this document. The focus of this work is on the cardiovascular responses to hypertension rather than the diagnosis of secondary hypertension. Sections address the pathophysiology of the cardiac and vascular responses to hypertension, measurement of LV mass, geometry, and function, as well as effects of treatment.

**Keywords** Hypertension • Echocardiography

## Table of Contents

Pathophysiology of cardiac responses to hypertension . . . . .	578	Measurement of LVM . . . . .	580
Left ventricular hypertrophy . . . . .	578	Linear echocardiographic dimensions . . . . .	580
Size and geometry of a normal heart. . . . .	578	Acquisition and measurements. . . . .	580
Effect of gender. . . . .	578	Normal values. . . . .	582
Effect of age. . . . .	579	Limitations. . . . .	582
Effect of exercise and sport. . . . .	579	Two-dimensional echocardiography . . . . .	582
Effect of obesity and diabetes. . . . .	579	Three-dimensional echocardiography . . . . .	583
Inherited and ethnic contributions. . . . .	579	Identification of LV geometric patterns . . . . .	583
LV hypertrophy due to increased load. . . . .	579	Concentric LV hypertrophy. . . . .	583
Adaptation of LV function to increased load . . . . .	579	Eccentric LV hypertrophy. . . . .	583
Morphology of the hypertensive heart. . . . .	580	Concentric remodeling. . . . .	583
LV morphology. . . . .	580	Other classification. . . . .	585
LA morphology. . . . .	580	Natural history of LV geometry in hypertension. . . . .	585

\* Corresponding author. Tel: +34 91 544 8940; Fax: +34 91 544 8940; E-mail: zamorano@secardiologia.es

<sup>†</sup> This document was co-chaired by T.H.M. and J.L.Z., on behalf of ASE and EACVI, respectively.

Published on behalf of the European Society of Cardiology. This article has been co-published in the Journal of the American Society of Echocardiography. All rights reserved. © The Author 2015.

Tissue characterization . . . . .	587
Arterial function and ventriculo-arterial matching . . . . .	589
Arterial function. . . . .	589
Arterial afterload. . . . .	589
Arterial afterload: pulse wave velocity and wave reflection. . . . .	589
Ventriculo-arterial interaction. . . . .	590
The classical approach to ventriculo-arterial matching. . . . .	590
Novel approaches to ventriculo-arterial matching. . . . .	590
Assessment of the aorta. . . . .	591
LV systolic function in hypertension . . . . .	592
Parameters from linear measurements. . . . .	592
Two-dimensional measurements . . . . .	592
Three-dimensional measurements . . . . .	592
Midwall function. . . . .	593
Rationale. . . . .	593
Validation and normal values. . . . .	593
Limitations. . . . .	593
Tissue Doppler assessment of systolic function . . . . .	593
Assessment of myocardial function by strain . . . . .	594
Prognostic significance of LV function in hypertension. . . . .	594
Chamber function. . . . .	594
LV midwall function in hypertension . . . . .	595
Diastolic function in hypertension . . . . .	595
Assessment of mitral inflow . . . . .	595
Acquisition and measurements. . . . .	595
Normal values. . . . .	595
Prognostic significance of mitral inflow patterns. . . . .	595
Tissue Doppler assessment of myocardial diastolic function . . . . .	595
Acquisition and measurements. . . . .	595
Normal values . . . . .	595
Prognostic significance of tissue Doppler parameters . . . . .	596
Cardiac impact of hypertension treatment . . . . .	596
LV hypertrophy regression . . . . .	596
Change in LV geometry . . . . .	596
Change in systolic function . . . . .	596
Change in diastolic function. . . . .	597
Echocardiography in clinical management of hypertension. . . . .	597
Stratification of risk in hypertension . . . . .	597
Investigation of chest pain symptoms. . . . .	597
Role in decision to initiate treatment. . . . .	598
Role in decisions to intensify treatment . . . . .	598
Use of echocardiography to monitor response to anti-hypertensive treatment . . . . .	598
Relevance of hypertension to echocardiographic interpretation . . . . .	599
Recommendations for clinical laboratories. . . . .	599
Recommendations for research studies and clinical trials. . . . .	599
Recommendations for echocardiography in hypertension clinical trials. . . . .	600
References . . . . .	601

## Pathophysiology of cardiac responses to hypertension

### Left ventricular hypertrophy

#### Size and geometry of the normal heart

The main contribution of echocardiography to the management of hypertension is the assessment of left ventricular (LV) mass (LVM).

Body habitus represents one of several factors that confound the association between hypertension and LVM. However, cardiac size is influenced by body size, and for any given size, men have larger hearts than women, athletes have larger hearts than non-athletes, and obese subjects have larger hearts than non-obese subjects.<sup>1</sup> LVM and volumes bear an approximately quadratic (rather than approximately cubic) relationship with height in men and women.<sup>2–4</sup>

In the enlarged heart, wall (fibre) stress increases with LV size (radius and volume). This increase is compensated by a proportional increase of wall thickness, so that wall stress remains matched with the systolic pressure. The 'relative' geometry of the ventricle appears to be similar across species and body size, with normal relative wall thickness [RWT, the ratio of twice the posterior wall thickness (PW) and the LV diastolic diameter] from 0.32 to 0.42.<sup>5</sup> Mass/volume ratios corresponding to the above-mentioned normal RWTs range between 1.1 and 1.3.<sup>5</sup> RWT and M/V do not require correction for body size.

#### Effect of gender

Data from several studies indicate that after adjustment for blood pressure and anthropometric parameters, LV volume and LVM are higher in men than in women.<sup>6–8</sup> These differences persist when values of LVM are corrected for fat-free mass.<sup>9</sup> This sex difference may explain the surprising lack of consensus in appropriate indexation of LVM, as it impacts the optimal method for indexing LVM for body height. *Figure 1* displays LVM, calculated by the Devereux formula (unidimensional 2D measurements) in the healthy reference subgroup of the Asklepios population.<sup>3</sup> Using the allometric index 1.7, the body

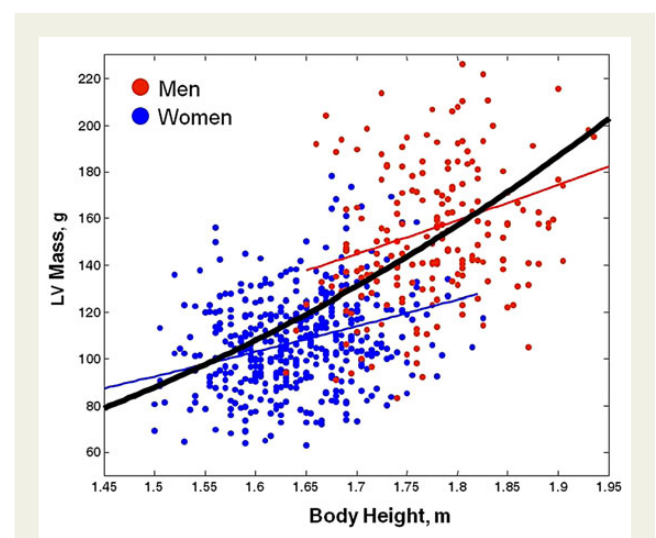

**Figure 1** Relationship between body height and LVM, calculated by the Devereux formula (unidimensional 2D measurements). Body height–LVM relationship in Asklepios reference participants assessed with nonlinear regression with and without accounting for the confounding effect of sex. The red line represents the body height–LVM relationship in men. The blue line represents the body height–LVM relationship in women. The black line represents the exaggeration of nonlinearity in the height–LVM relationship when the confounding effect of sex is neglected.<sup>3</sup> This particularly leads to estimation problems at the extremes.

height–LVM relationship in men (red) and women (blue) is parallel and indexation for body height is optimally achieved by height (ht)<sup>1,7</sup> in both sexes.<sup>3,10</sup> However, when an allometric exponent is computed for males and females considered together (thick black line) without adjustment for gender, there is an exaggeration of nonlinearity in the height–LVM relationship (allometric index 2.7). This has important clinical and epidemiological implications, resulting in marked overestimation of the prevalence of LV hypertrophy in short subjects and a marked underestimation in tall subjects. The appropriate indexation remains an issue of contention.<sup>11</sup>

### Effect of age

LV volumes are inversely associated with age. LVM decreases with age as well, albeit to a more limited extent than volume. As a consequence, RWT and M/V ratios increase. There is an age-related development of a concentric remodelling (see the Identification of LV Geometric Patterns section) with systolic and diastolic dysfunction.<sup>6,7,12</sup>

### Effect of exercise and sport

Isotonic exercise involves movement of large muscle groups. The profound vasodilatation of the skeletal muscle vasculature that is involved produces hypertrophy by increasing venous return to the heart and volume overload.<sup>13</sup> This hypertrophy is characterized by chamber enlargement and a proportional change in wall thickness, with no changes in RWT. In contrast, isometric or static exercise involves developing muscular tension against resistance with little movement. Reflex and mechanical changes cause a pressure load on the heart rather than a volume load resulting in a slightly enlarged ventricle with increased RWT hypertrophy.<sup>13</sup>

### Effect of obesity and diabetes

Obesity is associated with increased LV volumes, increased LVM, and most typically increased RWT.<sup>6,14,15</sup> In the Framingham study, an increase of body mass index over time was closely related to increased LVM and volumes.<sup>16</sup> Insulin resistance, metabolic syndrome, and diabetes mellitus type II are similarly associated with increased LVM, RWT, and diastolic dysfunction.<sup>6,17,18</sup> Diabetes patients have decreased systolic function as well.<sup>17–19</sup> Correction of LVM for height preserves both the effects of obesity and elevated blood pressures on LVM. In contrast, correction of LVM for body surface area (BSA) effectively corrects for not only height but also obesity-related LV hypertrophy, which will remain undetected.<sup>3,15</sup>

### Inherited and ethnic contributions

Some of the variance in LV dimensions and mass may be explained by heredity, independent of the effects of sex, age, body size, blood pressure, heart rate, medications, and diabetes.<sup>20</sup> Familial patterns of LV geometry were observed in subsequent generations of the Framingham study, but not in spouses.<sup>21</sup> The greatest inheritable risk was found for concentric remodelling.

Normal ranges of LVM differ across races, being larger in African-Americans than in white Americans and/or Hispanics and smaller in Asian-Americans.<sup>3,7</sup> Within one ethnicity, differences also exist between populations, e.g. Scandinavians being different from Mediterraneans. Only a part of these differences is accountable to ethnic variation in body size, and can be corrected by scaling.<sup>22</sup> It is still unclear to what extent ethnic differences prevail when scaling

for fat-free mass. It remains to be clarified to what extent these ethnic and population differences include a different prognosis and how to integrate ethnicities and populations in the definition of hypertrophy. At present, normal values and cutoffs should be adapted for each population.

### LV hypertrophy due to increased load

Two basic patterns of cardiac hypertrophy occur in response to haemodynamic overload.<sup>23</sup> In pressure overload (e.g. hypertension), pressure elevation most commonly leads to an increase in wall thickness and RWT, a phenomenon known as concentric remodelling (see the Identification of LV Geometric Patterns section). Eventually, an increase in systolic wall stress leads to concentric hypertrophy, caused by the addition of sarcomeres in parallel (hence, widening the cardiac myocytes), an increase in myocyte cross-sectional area, and an increase in LV wall thickening. In the Framingham Heart study, hypertensive patients had a greater increase in LVM and volume, and a smaller age-related reduction in LV size than individuals with normal blood pressure.<sup>16</sup> In contrast, eccentric hypertrophy due to volume overload (e.g. with mitral regurgitation) is caused by increased diastolic wall stress. This leads to an increase in myocyte length with the addition of sarcomeres in series (hence, lengthening of cardiac myocytes), thereby engendering LV enlargement.

### Adaptation of LV function to increased load

The complex changes that occur in the heart during LV remodelling cause alterations in LV size and geometry, but the process of LV remodelling also leads to alterations in contraction and relaxation, the volume of myocyte and non-myocyte components of the myocardium, the properties of the myocyte (sarcomeres, e.g. titin), and the extracellular matrix (balance of collagen types I and III, and collagen fraction). Diastolic function is influenced by alterations in LV systolic function and geometry, delayed myocardial relaxation, increased passive stiffness of the sarcomere and extracellular matrix, and altered myocardial tone.<sup>24</sup>

Cardiac myocyte hypertrophy leads to foetal gene reactivation and decreased expression of a number of genes normally expressed in the adult heart. Depending on age, sex, duration of hypertension, severity, and treatment, differing cellular and molecular events may underlie the evolution from a ventricle with concentric hypertrophy to a more dilated failing ventricle (often presenting as HFrEF, heart failure reduced ejection fraction) or to a heavily fibrotic and non-dilated ventricle (presenting as HFpEF, heart failure preserved ejection fraction), according to the three stages in the hypertrophic process (overload, hypertrophy, and failure).<sup>25</sup> Physiological hypertrophy (growth, pregnancy, and exercise) is characterized by normal organization of cardiac structure and normal or enhanced cardiac function, whereas pathological hypertrophy is commonly associated with upregulation of foetal genes, fibrosis, cardiac dysfunction, and increased mortality.<sup>13</sup> The continuous vs. intermittent nature of overload in the settings of pathological and physiological hypertrophy is unlikely to account for the differences in response.<sup>13</sup> In contrast to early-systolic load, late-systolic load delays myocardial relaxation<sup>26,27</sup> and induces more maladaptive hypertrophy.<sup>28</sup>

## Morphology of the hypertensive heart

### LV morphology

LV hypertrophy is defined on a normative basis; a definition based on 2 SD above the mean LVM in the general population will differ from a definition based on the healthy population without obesity or hypertension.<sup>3</sup> Separate cutoffs are required for men and women. If LVM is corrected for BSA, it should be recognized that this corrects for obesity-related LVM, or for height. In the end-stage hypertensive heart, there is an increase in LV volumes and sphericity, a decrease in stroke volume, and finally a reduction in EF.

### LA morphology

Left atrial (LA) volume may be calculated by either area-length or modified Simpson's methods, and is usually scaled for BSA and expressed in mL/m<sup>2</sup>; the normal range is up to and including 34 mL/m<sup>2</sup>.<sup>29</sup> As with the LV, scaling by BSA corrects for an obesity-related increase in LA size that as a consequence will remain undetected. The LA is not symmetrical, and enlargement may occur non-uniformly, predominantly in one direction. Consequently, LA size is much better evaluated with 2D- or 3D-based LA volume rather than with M-mode.<sup>30</sup> In hypertension and other situations where diastolic dysfunction occurs, reduction in early diastolic emptying is compensated by forceful atrial contraction. In addition, intermittent or permanent elevation of LV filling pressures leads to overfilling of the LA. The resulting LA enlargement is the 'morpho-physiologic expression' of chronic diastolic dysfunction, hypothesized to reflect the duration and severity of increased LA pressure. Although the presence

of atrial fibrillation itself contributes to atrial size, LA enlargement is a well-known independent determinant of stroke, cardiovascular events, and death.<sup>31</sup> Moreover, atrial fibrosis may be another endpoint of this process, predisposing to atrial remodelling and dysfunction with atrial fibrillation. This is a common endpoint that may be initiated by a number of aetiologies, including hypertension and diabetes mellitus.

The main determinants of an increasing atrial size with age are the cardiovascular risk factors of elevated blood pressure and obesity.<sup>31</sup> In hypertensive patients, LA enlargement is related to LVM (rather than the type of LV hypertrophy), overweight, higher fasting glucose, and metabolic syndrome.<sup>32</sup>

## Measurement of LVM

### Linear echocardiographic dimensions

#### Acquisition and measurements

The measurement of LVM requires accurate measurements of wall thickness and chamber dimensions, as described in the Chamber Quantification update.<sup>29</sup> The linear measurements of LV internal dimension (LVDd), septal (IVS), and PW are made from the parasternal long-axis acoustic window at the level of the LV minor axis, approximately at the mitral valve leaflet tips. M-mode recordings have excellent temporal resolution, and may be chosen from 2D images. However, even when directed by 2D guidance, it may not be possible to align the M-mode cursor perpendicular to the long axis of the ventricle (*Figure 2*). Software has been developed to

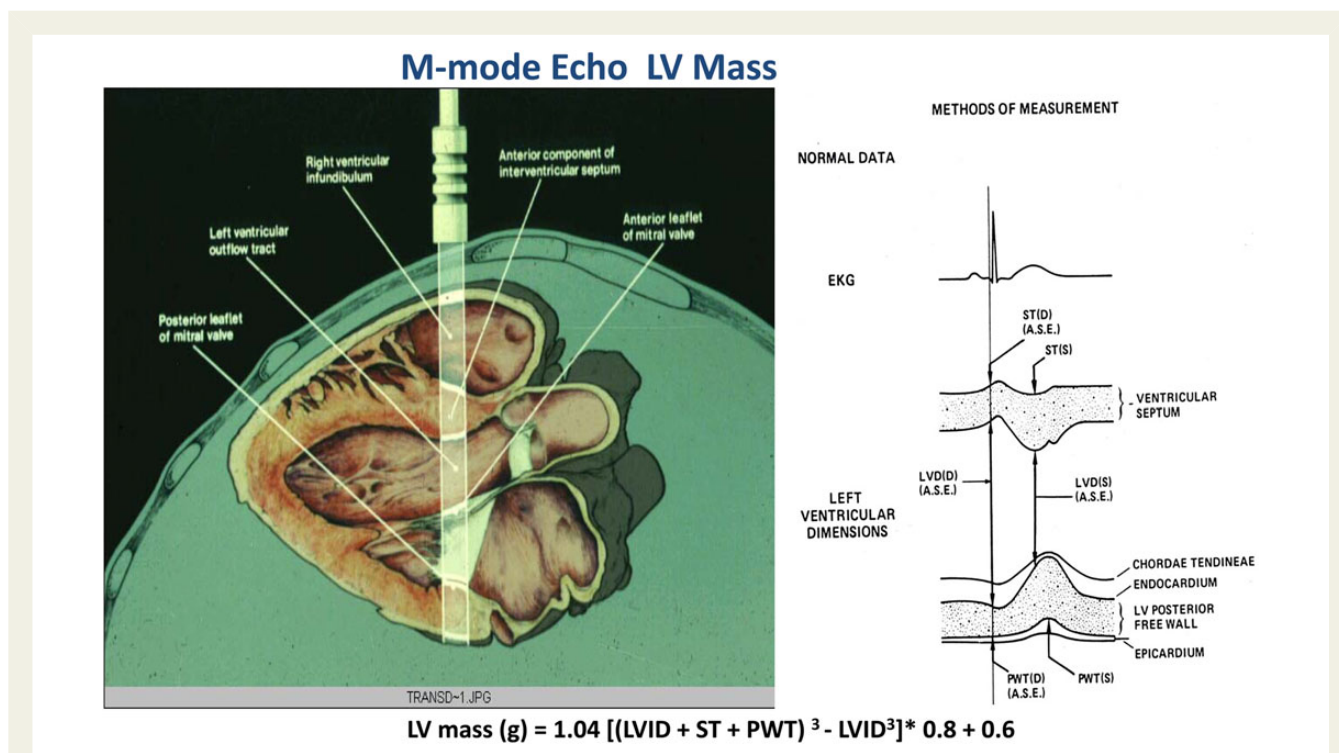

**Figure 2** The importance of on-axis imaging. Image shows alignment of the M-mode cursor perpendicular to the long axis of the ventricle. Orientation A is orthogonal to the LV long axis, but lacks an imaging window (the beam would have to pass through the sternum). Orientation B is tangential to the desired orthogonal LV axis and is unacceptable. If another window cannot be found, anatomical M-mode or direct 2D measurement may be required.

reconstruct anatomical M-mode images from 2D images (Figure 3), but this is not yet universally available. Reference normal values for LV linear measurements are published in the Chamber Quantification update.<sup>29</sup> Alternatively, chamber dimension and wall thicknesses can be acquired from the parasternal short-axis view using direct 2D measurements. The use of 2D-derived linear dimensions overcomes the common problem of oblique parasternal images resulting in overestimation of cavity and wall dimensions from M-mode (Figure 4).

When 2D measurements are used, the wall thicknesses and linear dimensions should be measured at the level of the LV minor dimension, at the mitral leaflet tips level. The upper limit of normal for LVDd is smaller than the M-mode measurement. Left ventricle internal dimension diastole (LVIDd), inter-ventricular septum diastole (IVSd), and posterior wall diastole (PWd) are measured at end-diastole from 2D or M-mode recordings, preferably on several beats.

Understanding the LVM literature is facilitated by recognizing various methods:

- (i) The original American Society of Echocardiography (ASE) approach recommended that dimensions be measured from the leading edge to the leading edge of echocardiographic borders. This results in the inclusion of endocardial echoes from the IVS and PW, and the exclusion of endocardial

echoes from the LVDd.<sup>33</sup> This was because the trailing edge of endocardial signals is dependent on gain settings. This may impact on LVM measurements, especially at the upper and lower extremes of these measurements.<sup>34</sup> The simplified calculation of LVM with this approach is  $LVM = 1.04[(IVS + LVDd + PW)^3 - (LVDd)^3] + 0.6$  g.

- (ii) The subsequent Penn convention excluded endocardial echoes from IVS and PW dimensions, but included endocardial echoes in measurement of the LVDd.<sup>35</sup> As the Penn convention gives larger cavity dimensions and smaller wall thicknesses than the ASE convention, the use of this approach necessitates subtraction of 13.6 from the previous mass calculation.
- (iii) The current ASE/European Association of Cardiovascular Imaging (EACVI) Chamber Quantitation Guidelines point out that refinements in image processing have allowed measurement of the actual visualized thickness of the ventricular septum and other chamber dimensions as defined by the actual tissue–blood interface, rather than the distance between the leading edge echoes, which had previously been recommended (Figure 5).<sup>29</sup>

All LVM algorithms (M-mode, 2D, or 3D echocardiographic measurements) are based on subtraction of the LV cavity volume

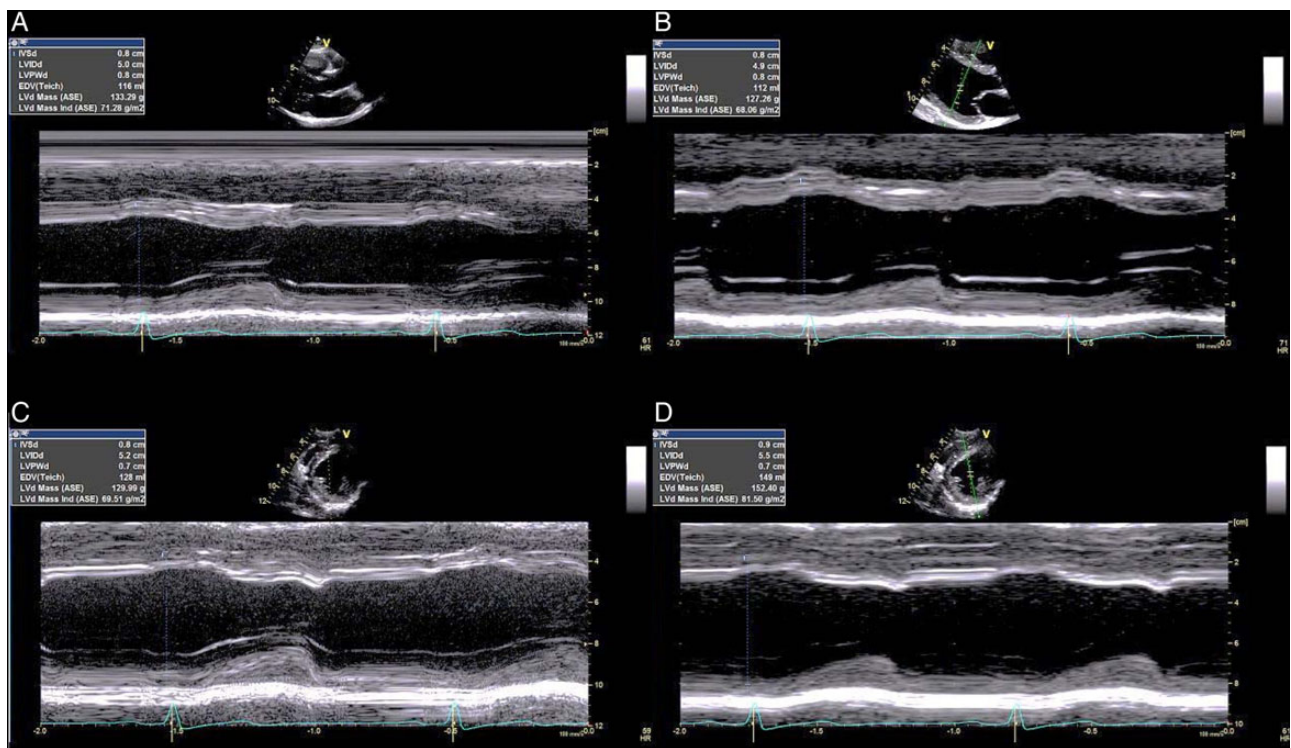

**Figure 3** Reconstruction of anatomical M-mode images from 2D images. Overestimation of LV dimensions can occur through tangential imaging at an angle to the appropriate axis (A). When the echo window cannot be moved, an alternative means of obtaining accurate data may be provided by reconstructing the M-mode dataset from the 2D image—so-called anatomical M-mode (B). In this example, a small (1 mm) difference in LV dimension results in a 5 g difference in LVM. Tangential imaging may not just relate to selection of a longer than expected cross-section—it may underestimate the measurement by failure of the beam to pass through the axis of the ventricle (C). Again, the use of anatomical M-mode imaging may circumvent this problem (D).

from the volume enclosed by the LV epicardium to obtain the volume of the shell between the LV cavity and the epicardial surface. This shell volume is then converted to mass by multiplying LV wall volume by the specific gravity of myocardium (1.05 g/mL). The formula used for estimation of LVM from LV linear dimensions is based on modeling the LV as a prolate ellipse, and assumes that the major/minor axis ratio is 2:1:  $LVM = 0.8 \times \{1.04[(LVIDd + PW + IVSd)^3 - (LVIDd)^3] + 0.6\}$  g. Extensive validation of this formula has been performed from necropsy specimens.<sup>36</sup>

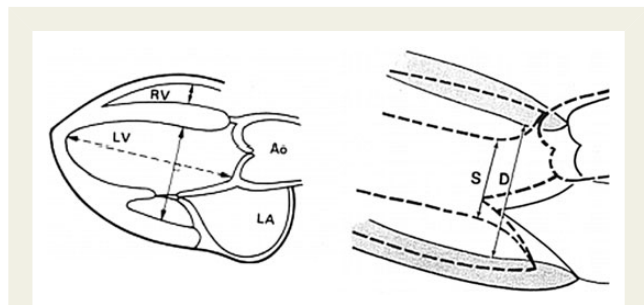

**Figure 4** Use of 2D images for diastolic and systolic measurements aligned orthogonal to the ventricular long axis at the junction of chordae and mitral leaflets.

**Normal values**

Table 1 summarizes the reported range of normal values for LVM by M-mode echocardiography.<sup>3,37–45</sup> These values differ between men and women, with the latter systematically lower than the former, even when indexed for BSA (Table 1; see the section below—methods of indexation). The upper limits of normal ranges in the ASE chamber quantification update are >95 g/m<sup>2</sup> (>44 g/ht<sup>2.7</sup>) in women and >115 g/m<sup>2</sup> (>48 g/ht<sup>2.7</sup>) in men.<sup>29</sup>

**Limitations**

There are four principal limitations in the calculation of LVM using linear methods:

- (i) The ‘Cube’ formula is not accurate in patients with major distortions of LV geometry (e.g. apical aneurysm, or any condition where the 2:1 axis ratio requirement is not met).
- (ii) Because this formula involves cubing primary measurements, even small errors in these measurements may be magnified.
- (iii) These measurements are insensitive to small changes in mass.
- (iv) The measurements are highly dependent on imaging quality and observer expertise.

**Two-dimensional echocardiography**

The most commonly used 2D methods for measuring LVM are based on the area-length formula and the truncated ellipsoid

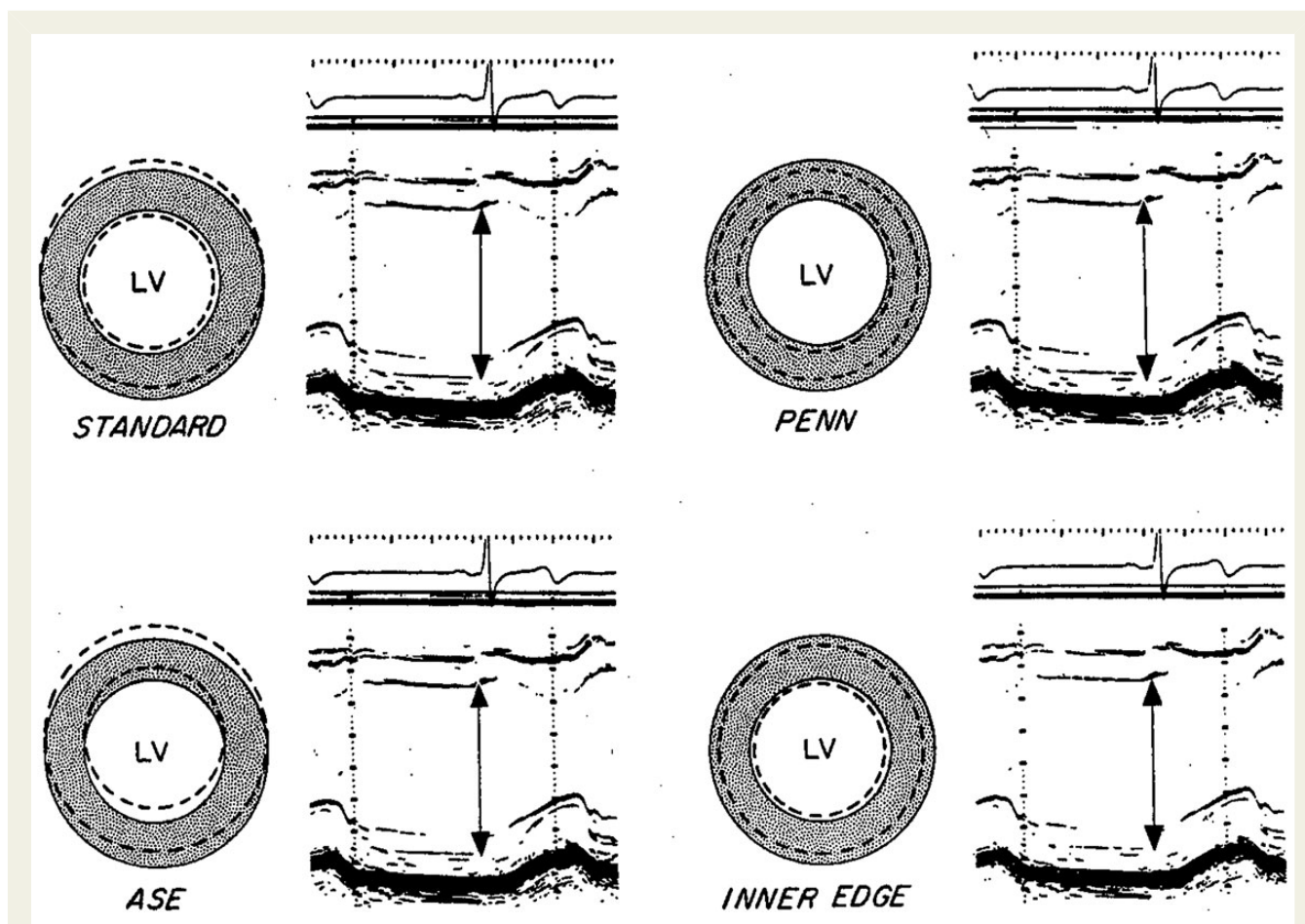

**Figure 5** Range of measurement options for measuring LVM.

model, as described in detail in the previous ASE/EACVI chamber quantification document<sup>46</sup> (Figure 6). In the presence of shape distortions, such as that caused by post-myocardial infarction (MI) remodelling, the geometric assumptions inherent in this approach remain problematic. Both methods were validated in the early 1980s in animal models and by comparing pre-mortem echocardiograms with measured LV weight at autopsy in human beings. Normal values are summarized in Table 2,<sup>47,48</sup> and the degrees of abnormality are classified in Table 3. The main limitations relate to image quality and the temporal resolution of 2D imaging, compared with M-mode echocardiography. The limitations of M-mode regarding geometrical assumptions and the impact of small error on measurements are also applicable to 2D measurements. In addition, 2D imaging leads to frequent foreshortening due to inappropriate cut-planes.

### Three-dimensional echocardiography

The benefit of three-dimensional echocardiography (3DE) is especially to obviate inaccurate geometric assumptions, inherent to 2DE, that become exaggerated in remodelled ventricles. 3DE is a potentially attractive modality for the measurement of LVM, and normal ranges have been developed.<sup>49</sup> The accuracy of 3DE is reportedly similar to cardiac magnetic resonance (CMR) imaging methods for measuring LVM.<sup>50–52</sup> However, there are wide limits of agreement which primarily relate to difficulties in accurately tracing the LV epicardial border, particularly in dilated ventricles,<sup>53</sup> and generally show that while 3DE is imperfect for LVM estimation—with a tendency to underestimate LVM compared with CMR imaging in patients with cardiac disease—the accuracy is more favourable than with alternative ultrasound methods. Normal values of M-mode, 2D mass, and 3D mass are given in Tables 1 and 2. Degrees of abnormality of LVM are summarized in Table 3 and the validation of all methods against reference techniques is summarized in Table 4. A later section describes the use of 2D and 3D for the assessment of LV function.

#### Recommendations

LVM is prognostically important and should be reported in hypertensive patients.

In the normally shaped LV, either M-mode or 2DE formulas can be used to calculate LVM. The majority of community-acquired prognostic evidence has been gathered with M-mode imaging.

In laboratories that use 3DE routinely, 3D LVM measurement should be considered—especially in abnormally shaped ventricles or in individuals with asymmetric or localized hypertrophy. 3DE is the only echocardiographic technique that measures myocardial volume directly, without geometric assumptions about LV shape and distribution of wall thickening.

### Identification of LV geometric patterns

While patients with early hypertensive disease will most likely have normal LV geometry,<sup>54</sup> longstanding or untreated hypertension will result in changes in LV shape and eventually, a deterioration of systolic

function. Broadly, the changes in LV geometry can be classified according to whether LVM is normal or increased and whether ventricular morphology (RWT) is altered<sup>46</sup> (Table 5). RWT is variably reported as  $(PW * 2)/LVd$  or  $(IVS + PW)/LVd$ , of which we favour the former because septal measurements may be confounded by the presence of septal bulge. RWT is problematic and not reflective of true LV geometry in patients with asymmetric hypertrophy. The upper limit of normal RWT is 0.42.<sup>29</sup>

### Concentric LV hypertrophy

Concentric LV hypertrophy, probably most commonly associated with hypertension, is characterized by normal cavity size, uniformly increased LV wall thickness, and increased LVM (Figures 7 and 8).<sup>46</sup> Cutoff values adopted by the ASE and EACVI are based on either overall LVM (g), LVM/BSA ( $g/m^2$ ), LVM/height ( $g/m$ ), or LVM/height<sup>2.7</sup> ( $g/m^{2.7}$ ) and while each has been shown to have limitations of either under- or overestimating LVM, each has been used successfully in characterizing LV hypertrophy in different patient populations.

Concentric LV hypertrophy is an adaptive response to high systemic pressure caused by hypertension or diseases such as aortic stenosis, coupled with high peripheral resistance. Concentric LV hypertrophy (LVH) and changes in LV geometry have been shown to affect both men and women regardless of age,<sup>55</sup> and are also associated with changes in diastolic function, longitudinal and radial myocardial function, and atrial size.<sup>56–58</sup>

### Eccentric LV hypertrophy

In contrast to concentric LVH, eccentric hypertrophy is associated with volume, rather than pressure overload. This is usually due to significant valvular regurgitation or high cardiac index, as is seen in elite athletes (although concentric hypertrophy may be the consequence of strength training). Systemic pressure is normal and peripheral resistance is not increased in patients with eccentric hypertrophy. Echocardiographic findings show increased LV cavity size, normal LV wall thickness, and increased LVM (Figure 9). Patients with eccentric hypertrophy share similar changes in diastolic function and longitudinal and radial function as those with concentric hypertrophy.<sup>55,57,58</sup> Unlike concentric hypertrophy, however, patients with eccentric LVH generally have low normal or mildly impaired systolic function due to chronic volume overload.

Changes in LV shape associated with LV enlargement have been quantified as sphericity index. This is a ratio between measured end diastolic volume (EDV) (preferably with 3DE) and a spherical volume based on the longitudinal dimension of the LV ( $4/3 * \pi * D/2$ ).<sup>2</sup> This parameter has been shown to be a predictor of remodelling, but this is more in the setting of LV dysfunction after MI than in hypertensive heart disease.<sup>59</sup>

### Concentric remodelling

Concentric LV remodelling is a late stage response of the LV and can be caused by chronic pressure, volume overload, or MI. It is most commonly associated with coronary artery disease, but is also associated with longstanding hypertension, especially untreated hypertension.<sup>60</sup> Like eccentric hypertrophy, it is also associated with LV systolic dysfunction. Echocardiographic features show normal or small LV cavity size, usually increased LV wall thickness and normal

**Table 1** Normal limits of M-mode LVM

Source	Year	Men	Women	Age (years)	Body size indexation	Measurement convention	LVM		Upper limit of LVMI		Basis for upper limits
							Men	Women	Men	Women	
Henry et al. <sup>37</sup>	1980	78	58	20–97	None	ASE	160 ± 25 * g (107 ± 17 g/m <sup>2</sup> )		210 * g (140 g/m <sup>2</sup> )		95% CL
Devereux et al. <sup>38</sup>	1981	106	120	39 ± 13	BSA	Penn	89 ± 21	69 ± 19	136 g/m <sup>2</sup>	112 g/m <sup>2</sup>	97th percentile
Hammond et al. <sup>39</sup>	1984	83	77	44 ± 13	BSA	Penn	155 ± 50 g (Penn) 193 ± 55 g (ASE) 84 ± 23 g/m <sup>2</sup> (Penn)	–	134 g/m	110 g/m <sup>2</sup>	Comparison with hypertensive population: LV determination
Byrd et al. <sup>40</sup>	1985	44	40	35 ± 10	BSA	–	148 ± 26 g 76 ± 13 g/m <sup>2</sup>	108 ± 21 g 66 ± 11 g/m <sup>2</sup>	200 g 102 g/m <sup>2</sup>	150 g 88 g/m <sup>2</sup>	95th percentile
Levy et al. <sup>41</sup>	1987	347	50	43 ± 12	Ht/BSA	ASE	208 ± 43 g (ASE) 177 ± 41 g (Penn)	145 ± 27 g (ASE) 118 ± 24 g (Penn)	294 g 163 g/m	198 g 121 g/m	M + 2 SD
Koren et al. <sup>42</sup>	1991	167	86	47 ± 13	BSA	Penn	–	–	125 g/m <sup>2</sup>	125 g/m <sup>2</sup>	CV risk at 10 years
de Simone et al. <sup>43</sup>	1992	137	91	39 ± 14	None	Penn	155 ± 34 g	117 ± 28 g	223 g	173 g	M + 2 SD
					Height	Penn	89 ± 19 g/m	72 ± 17 g/m <sup>2.7</sup>	127 g/m <sup>2.7</sup>	106 g/m <sup>2</sup>	M + 2 SD
					Height <sup>2.7</sup>	Penn	35 ± 8 g/m <sup>2.7</sup>	32 ± 8 g/m <sup>2</sup>	51 g/m <sup>2</sup>	48 g/m <sup>2</sup>	M + 2 SD
					BSA	Penn	89 ± 16 g/m <sup>2</sup>	73 ± 16 g/m <sup>2</sup>	117 g/m <sup>2</sup>	105 g/m <sup>2</sup>	M + 2 SD
Kuch et al. <sup>44</sup>	2000	213	291	42 ± 12	Height	ASE	97 ± 21 g/m	71 ± 18 g/m	139 g/m	107 g/m	M + 2 SD
					Height <sup>2.7</sup>	ASE	37 ± 8 g/m <sup>2.7</sup>	31 ± 8 g/m <sup>2.7</sup>	53 g/m <sup>2.7</sup>	47 g/m <sup>2.7</sup>	M + 2 SD
					BSA	ASE	89 ± 18 g/m <sup>2</sup>	70 ± 17 g/m <sup>2</sup>	135 g/m <sup>2</sup>	104 g/m <sup>2</sup>	M + 2 SD
					FFM	ASE	2.91 ± 0.59 g/kg	2.71 ± 0.70 g/kg	4.09 g/kg	4.11 g/kg	M + 2 SD
CV Health Study <sup>45</sup>	2001	651	1066	72 ± 5 (65–98)	None	ASE	166 ± 45 g	127 ± 35 g	256 g	197 g	M + 2 SD
					Height	ASE	96 ± 27 g/m	80 ± 22 g/m	150 g/m	124 g/m	M + 2 SD
					Height <sup>2.7</sup>	ASE	37 ± 11 g/m <sup>2.7</sup>	36 ± 10 g/m <sup>2.7</sup>	59 g/m <sup>2.7</sup>	56 g/m <sup>2.7</sup>	M + 2 SD
					BSA	ASE	87 ± 24 g/m <sup>2</sup>	77 ± 19 g/m <sup>2</sup>	135 g/m <sup>2</sup>	115 g/m <sup>2</sup>	M + 2 SD
CV Health Study (Healthy Substudy)	2013	93	213	75 ± 4	None	ASE	146 ± 36 g	121 ± 32 g	218 g	185 g	M + 2 SD
					Height	ASE	84 ± 20 g/m	76 ± 20 g/m	124 g/m	116 g/m	M + 2 SD
					Height <sup>2.7</sup>	ASE	33 ± 9 g/m <sup>2.7</sup>	34 ± 9 g/m <sup>2.7</sup>	51 g/m <sup>2.7</sup>	52 g/m <sup>2.7</sup>	M + 2 SD
					BSA	ASE	77 ± 19 g/m <sup>2</sup>	74 ± 19 g/m <sup>2</sup>	115 g/m <sup>2</sup>	114 g/m <sup>2</sup>	M + 2 SD
Asklepios—total population <sup>3</sup>	2007	1301	1223	46 (41–51) (35–55)	None	2D	175 ± 39 g	121 ± 30 g	243 g	177 g	95th percentile
					Height <sup>1.7</sup>	2D	67 ± 15 g/m <sup>1.7</sup>	53 ± 13 g/m <sup>1.7</sup>	92 g/m <sup>1.7</sup>	77 g/m <sup>1.7</sup>	95th percentile
					BSA	2D	87 ± 17 g/m <sup>2</sup>	69 ± 14 g/m <sup>2</sup>	116 g/m <sup>2</sup>	94 g/m <sup>2</sup>	95th percentile
Asklepios Healthy, Risk factor deprived <sup>3</sup>	2007	198	414	43 (39–48) (35–55)	None	2D	155 ± 36 g	108 ± 21 g	214 g	143 g	95th percentile
					Height <sup>1.7</sup>	2D	58 ± 13 g/m <sup>1.7</sup>	46 ± 9 g/m <sup>1.7</sup>	81 g/m <sup>1.7</sup>	60 g/m <sup>1.7</sup>	95th percentile
					BSA	2D	82 ± 17 g/m <sup>2</sup>	65 ± 11 g/m <sup>2</sup>	112 g/m <sup>2</sup>	86 g/m <sup>2</sup>	95th percentile

CHS healthy subgroup: no prevalent HF, CVD, hypertension, obesity, or subclinical heart disease (i.e. normal aortic augmentation index and normal carotid intima-media thickness).



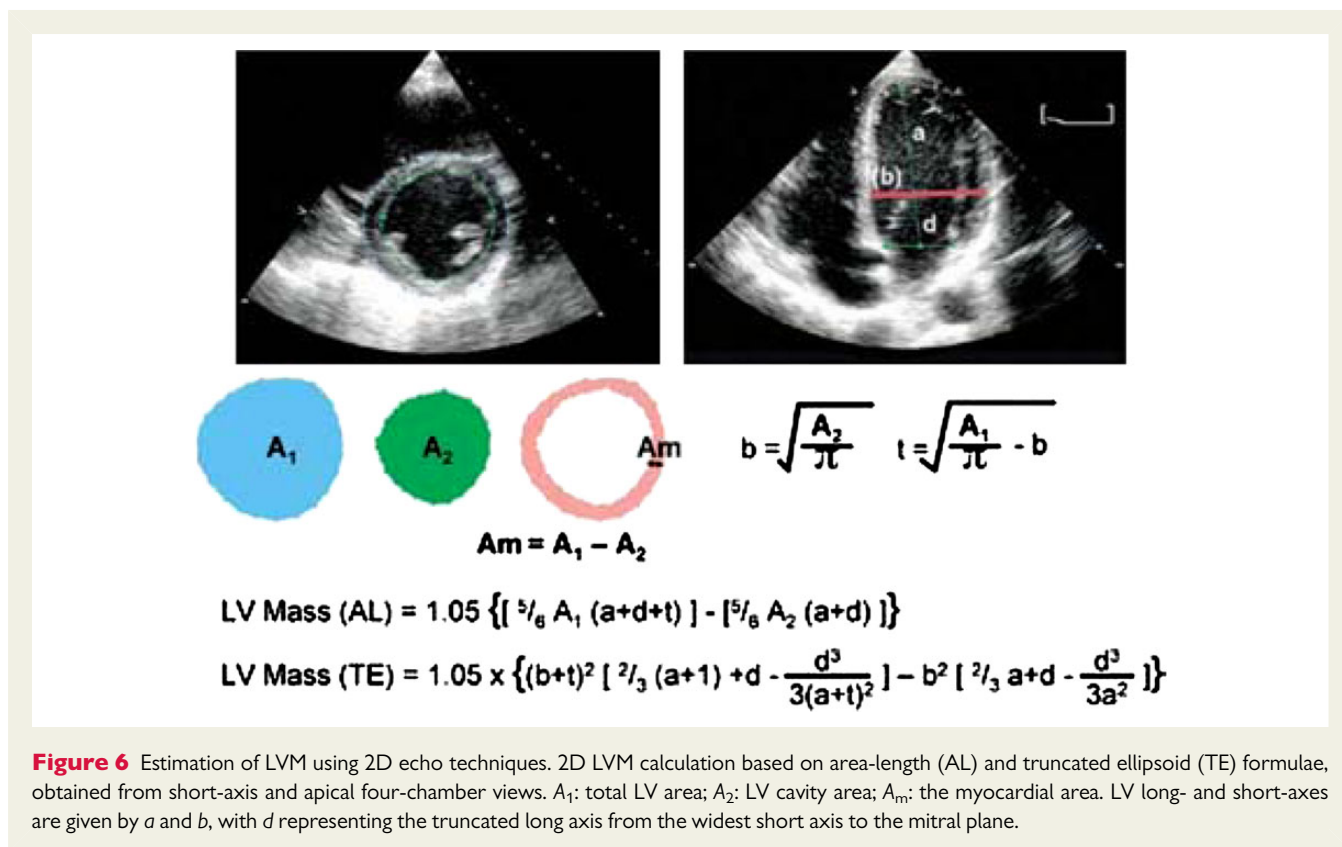

**Table 2** Normal values (mean ± SD) for LVM by 2D and 3D echo<sup>29,48,49</sup>

	European		Japanese	
	Men	Women	Men	Women
2D LVM (g)	96–200	66–150		
2D LVM index (g/m <sup>2</sup> )	50–102	44–88		
3D LVM (g)				
3D LVM index (g/m <sup>2</sup> )	77 (57–97)	74 (58–90)	64 (40–88)	56 (34–78)

LVM (Figures 7 and 10). Concentric remodelling is also associated with changes in the shape of the LV—e.g. LV sphericity changes—and becomes more rounded, rather than bullet shape.<sup>1</sup> The result of this is more dramatic degradation of diastolic function and loss of radial and longitudinal function.<sup>57</sup>

### Other classification

The limitation of the classical categories is the suboptimal categorization of dilated ventricles.<sup>61</sup> Recently, Gaasch and Zile<sup>5</sup> proposed a subdivision based on LVM (vertical axis), LV volume (horizontal axis), and RWT or M/V, represented by the oblique lines indicating the upper (full) and lower (dashed) limit of normality (Table 6 and Figure 7). Using this approach, the non-dilated ventricle is characterized as having normal morphology, concentric remodelling, or

concentric hypertrophy, based on LVH and RWT (>0.42). Dilated ventricles without LVH are described as having eccentric remodelling if the RWT is <0.32. Dilated ventricles with LVH are described as having eccentric hypertrophy (RWT <0.32), mixed hypertrophy (RWT >0.42), or physiological hypertrophy (RWT 0.32–0.42). The resulting categories yield distinct functional behaviours and prognoses.

### Natural history of LV geometry in hypertension

Left ventricular hypertrophy is caused by increased wall stress, either due to chronic pressure overload, as seen in hypertension, or the volume overload seen in valvular disease. However, in early, mild hypertension, LVH is usually absent and the first manifestation of

**Table 3** Degrees of abnormality of LVM

	Women				Men			
	Reference range	Mildly abnormal	Moderately abnormal	Severely abnormal	Reference Range	Mildly abnormal	Moderately abnormal	Severely abnormal
Linear method								
LVM, g	67–162	163–186	187–210	≥211	88–224	225–258	259–292	≥293
<b>LVM/BSA, g/m<sup>2</sup></b>	43–95	96–108	109–121	≥122	49–115	116–131	132–148	≥149
LVM/height, g/m	41–99	100–115	116–128	≥129	52–126	127–144	145–162	≥163
LVM/height <sup>2.7</sup> , g/m <sup>2.7</sup>	18–44	45–51	52–58	≥59	20–48	49–55	56–63	≥64
Relative wall thickness, cm	0.22–0.42	0.43–0.47	0.48–0.52	≥0.53	0.24–0.42	0.43–0.46	0.47–0.51	≥0.52
Septal thickness, cm	0.6–0.9	1.0–1.2	1.3–1.5	≥1.6	0.6–1.0	1.1–1.3	1.4–1.6	≥1.7
Posterior wall thickness, cm	0.6–0.9	1.0–1.2	1.3–1.5	≥1.6	0.6–1.0	1.1–1.3	1.4–1.6	≥1.7
2D method								
LVM, g	66–150	151–171	172–182	>193	96–200	201–227	228–254	>255
<b>LVM/BSA, g/m<sup>2</sup></b>	44–88	89–100	101–112	≥113	50–102	103–116	117–130	≥131

BSA, body surface area; LV, left ventricular; 2D, two-dimensional.  
 Bold italic values: recommended and best validated.

**Table 4** Correlation of all echocardiographic methods of LVM calculation vs. MRI

	End-diastole				End-systole			
	r	SEE (g)	P-value	Regression equation	r	SEE (g)	P-value	Regression equation
1D Echo-Penn vs. CMR	0.725	25.6	0.018	1D Echo-Penn = 0.99 (CMR) + 4.0	0.788	28.7	0.007	1D Echo-Penn = 1.35 (CMR) – 19.2
2D Echo-AL vs. CMR	0.694	24.2	0.030	2D Echo-AL = 0.86 (CMR) + 32.4	0.717	28.2	0.030	2D Echo-AL = 1.10 (CMR) + 14.1
2D Echo-TE vs. CMR	0.687	21.8	0.030	2D Echo-TE = 0.76 (CMR) + 27.7	0.710	24.5	0.020	2D Echo-TE = 0.90 (CMR) + 13.0
3D Echo-PSR vs. CMR	0.882	10.4	0.001	3D Echo-PSR = 0.72 (CMR) + 32.2	0.908	10.8	0.001	3D Echo-PSR = 0.86 (CMR) + 13.2

CMR, magnetic resonance imaging; 1D Echo-Penn, M-mode echocardiographic method (Penn convention); 2D Echo-AL, two-dimensional echocardiographic area-length method; 2D Echo-TE, two-dimensional echocardiographic truncated ellipsoid method (8); 3D Echo-PSR, three-dimensional echocardiographic polyhedral surface reconstruction method.

**Table 5** Classical description of LV geometry

LV geometry	LVM	RWT
Normal	≤115 g/m <sup>2</sup> (men) or ≤95 g/m <sup>2</sup> (women)	<0.42
Concentric hypertrophy	>115 g/m <sup>2</sup> (men) or >95 g/m <sup>2</sup> (women)	>0.42
Eccentric hypertrophy	>115 g/m <sup>2</sup> (men) or >95 g/m <sup>2</sup> (women)	<0.42
Concentric remodelling	≤115 g/m <sup>2</sup> (men) or ≤95 g/m <sup>2</sup> (women)	>0.42

Measurements performed using 2D-directed M-mode.<sup>29</sup>

hypertension is diastolic dysfunction.<sup>58,62</sup> This can be detected as grade 1 diastolic impairment, or impaired relaxation. Over time however, if left untreated, filling pressures continue to rise, ventricular hypertrophy develops as an adaptive response to chronic

pressure, and more severe disturbances of diastolic filling are more commonly encountered. Eventually, LV remodelling will occur and left ventricular systolic function will become impaired. While the goal of hypertension management is to prevent any changes in LV

geometry, the current ability of echocardiography to provide serial assessment of the LV response in the individual patient is compromised by variability of LVM measurement.

**Recommendations**

Description of LV geometry, using at the minimum the four categories of normal geometry, concentric remodelling, and concentric and eccentric hypertrophy, should be a standard component of the echocardiography report.

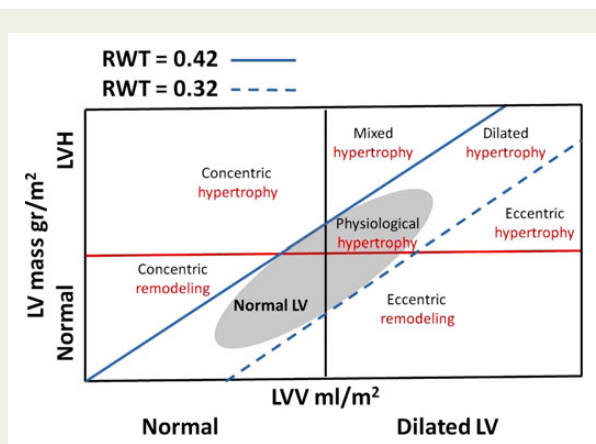

**Figure 7** LV geometric patterns classified according to LVM, LV volume, and RWT. The red horizontal line separates LVH from normal LVM. The black vertical line separates dilated from non-dilated ventricles. The two oblique blue lines delimit the upper (0.42) and lower (0.32) limit of normal RWT. This leads to eight categories of ventricles. The grey ellipse indicates the area of normal ventricles including physiological LV enlargement.

**Tissue characterization**

The haemodynamic disturbances and humoral stimulation that lead to the cardiac responses to hypertension<sup>63</sup> do not necessarily progress in parallel.<sup>64</sup> While measurement of LVM addresses the response to haemodynamic disturbance, this may not necessarily reflect the full physiological impact of hypertension on the heart. While not part of current guidelines, tissue characterization may provide information about myocardial remodelling, and allow targeted therapy against molecular changes, sarcoplasmic failure, apoptosis, fibrosis, and disturbances of vascular structure and function.<sup>65</sup> Interstitial, perivascular, plexiform, and replacement fibrosis of necrotic tissue<sup>66</sup> are likely responsible for disturbances of myocardial perfusion, synchrony, and rhythm.

An important reason for attempting to characterize myocardial tissue is that not all increments in LVM that occur in the setting of hypertensive heart disease are due to hypertension. The recognition of other causes of increased wall thickness, including athletic hypertrophy, valvular disease, infiltrative disorders (amyloid, Friedrich's ataxia, and Fabry's disease), non-compaction, and hypertrophic cardiomyopathy,<sup>67</sup> has important treatment implications.

Tests of myocardial tissue characterization can be divided into processes that measure tissue reflection (and therefore tissue density), and functional changes that are due to the dynamic consequences of changes in myocardial ultrastructure (which are discussed in the section on LV function). The only echocardiographic marker of tissue density is integrated backscatter, a measure of ultrasonic scatter from small reflectors, which relate to tissue density.<sup>68</sup> Calibrated integrated backscatter refers to a method whereby the amplitude of reflection is measured in relation to the amplitude deriving from a reference tissue, for example, blood within the LV cavity or the pericardium. The primary determinant of both scatter and attenuation in myocardial tissue is collagen.<sup>69</sup> However, as scatter is also related to position and orientation of myofibrils relative to the ultrasound beam, variations in these measurements are not specific for

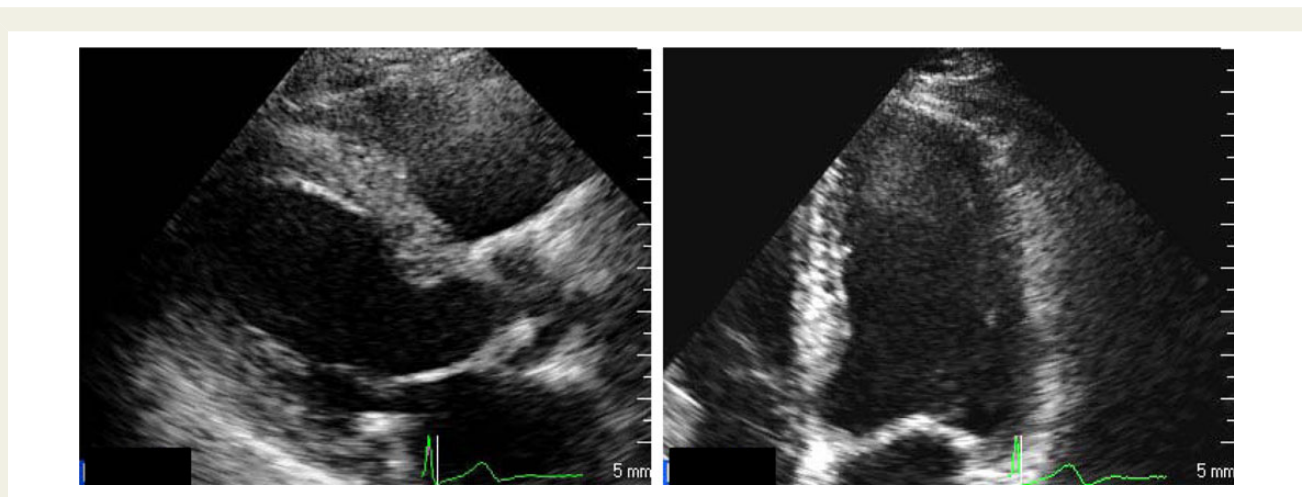

**Figure 8** Concentric LVH. Parasternal long-axis (left) and apical four-chamber views (right) from a 55-year-old hypertensive male patient with concentric LVH. LVDd 48 mm; LVDs 34 mm; IVS 18 mm; PW 15 mm; EF 60%; LVM 268 g.

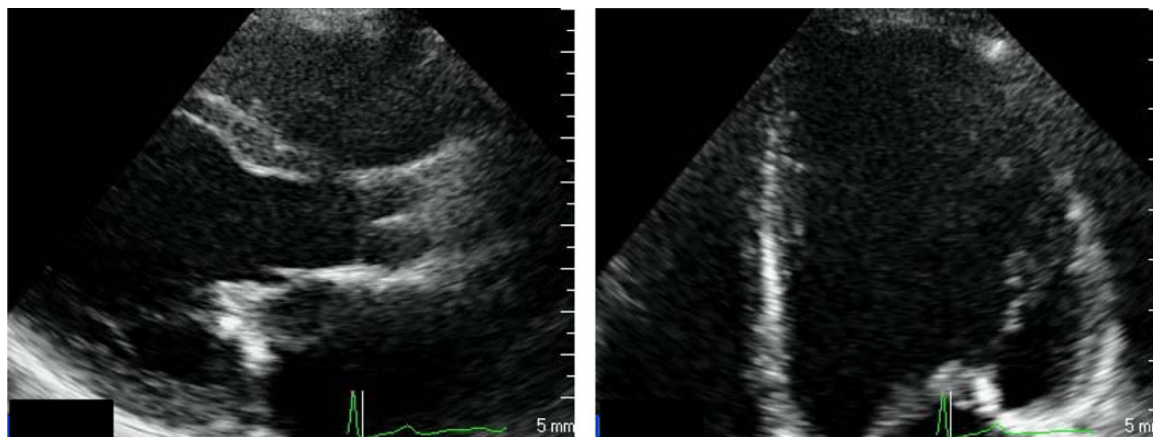

**Figure 9** Eccentric LVH. Parasternal long-axis view (left) and apical four-chamber view (right) of a 28-year-old female patient with a failed mitral valve repair showing eccentric LVH. LVDD 56 mm; LVDs 39 mm; IVS 12 mm; PW 12 mm; EF 50%; LVM 206 g.

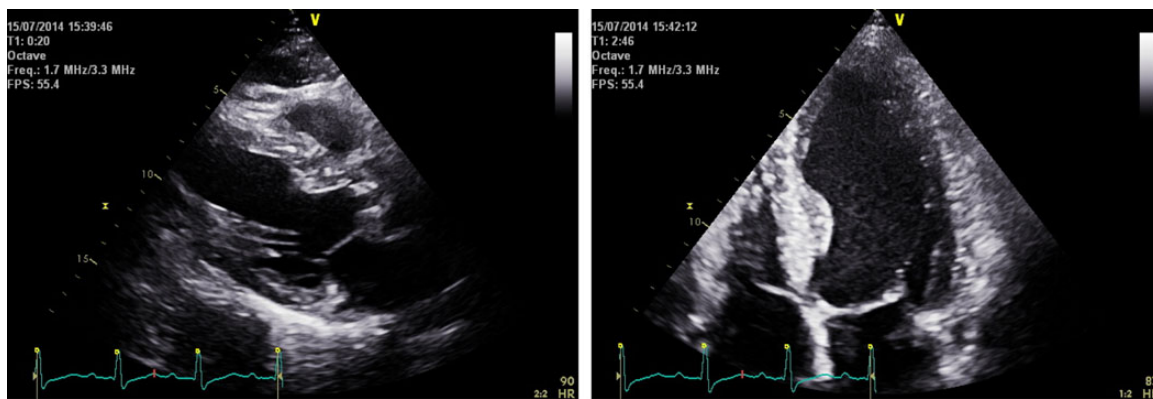

**Figure 10** Concentric LV remodelling. A 59-year-old male patient with concentric LV remodelling. LVEDD 47 mm; LVESD 36 mm; IVS 20 mm; PW 11 mm; EF 43%; LVM 270 g.

**Table 6** Characterization of LV geometry based on LVM (vertical axis), LV volume (horizontal axis), and RWT, measured using 2D-directed M-mode<sup>29</sup>

LV geometric pattern	LV volume index (mL/m <sup>2</sup> )	LVM index (g/m <sup>2</sup> )	RWT
Normal ventricle	≤75	≤115 (men) or ≤95 (women)	0.32–0.42
Physiological hypertrophy	>75	>115 (men) or >95 (women)	0.32–0.42
Concentric remodelling	≤75	≤115 (men) or ≤95 (women)	>0.42
Eccentric remodelling	>75	≤115 (men) or ≤95 (women)	<0.32
Concentric hypertrophy	≤75	>115 (men) or >95 (women)	>0.42
Mixed hypertrophy	>75	>115 (men) or >95 (women)	>0.42
Dilated hypertrophy	>75	>115 (men) or >95 (women)	0.32–0.42
Eccentric hypertrophy	>75	>115 (men) or >95 (women)	<0.32

fibrosis and backscatter and attenuation is also affected by angle of insonation (i.e. the same myocardial segment will have different ultrasound characteristics when viewed from orthogonal windows—parasternal long axis vs. apical) due to the alignment of myofibrils perpendicular or parallel to the ultrasound beam. Thus, feasibility can be limited.<sup>70</sup> Moreover, these changes in early hypertensive heart disease may be subtle.<sup>71</sup>

Two other imaging methods are probably superior to echocardiography for myocardial tissue characterization. Late gadolinium enhancement with CMR has become widely used for the recognition of replacement fibrosis in ischaemic heart disease.<sup>72</sup> The same has also been helpful in understanding the contribution of fibrosis in hypertrophy, where ~50% of patients with hypertensive LVH manifest patchy late enhancement,<sup>73</sup> which correlates with the presence of diastolic dysfunction.<sup>74</sup> The problem with this technique is that it is based on defining a reference normal segment within the myocardium, so it may be misleading for the detection of diffuse interstitial fibrosis. A potential solution is the use of  $T_1$  mapping, which allows the recognition of differences in  $T_1$  relaxation between the normal and fibrotic myocardium. Recent work has validated  $T_1$  mapping as an accurate marker of the extent of diffuse fibrosis.<sup>75</sup> The final methods that are used in tissue characterization are 'cardiac nuclear imaging' procedures for molecular imaging of collagen<sup>76</sup> and detection of apoptosis.<sup>77</sup>

Other echocardiographic markers—for example tissue Doppler and strain—have been used as markers of fibrosis.<sup>66</sup> It should be recognized that these functional parameters may be confounded by myocardial processes that parallel the development of fibrosis, and may not be optimal for this purpose.<sup>78</sup>

### Recommendations

Myocardial characterization using CMR can identify non-hypertrophic causes of LV thickening. It should be considered when (i) the degree of LV thickening is at least moderate, (ii) severity of the LV thickening is inconsistent with the severity of hypertension, (iii) there is evidence of LV dysfunction despite appropriate BP control, (iv) other features raise the prospect of an infiltrative process (severe thickening, alteration of tissue density on fundamental imaging, or  $e'$  velocity <5 cm/s).

## Arterial function and ventriculo-arterial matching

### Arterial function

#### Arterial afterload

Arterial afterload is characterized by both steady and pulsatile components of blood pressure.<sup>79</sup> This parameter is determined by impedance, compliance, or resistance, derived from aortic pressure ( $P_{ao}$ ) and flow waveforms ( $F_{ao}$ ), both of which can be assessed non-invasively by means of applanation tonometry and ultrasound, respectively.

A variety of measurements have been created to better understand the process of displacement of blood from the LV into the arterial tree (Figure 11). If the arterial system was composed of rigid tubes without any storage capacity, blood would be accelerated in

stysole throughout the complete arterial tree, which would give rise to very large intra-arterial pressure differences (and a high load on the heart). Owing to the elasticity of the large arteries, however, part of the stroke volume is locally stored in the aorta in systole (the 'windkessel' function), buffering the pulsatility of blood flow and providing a more continuous blood flow in the distal circulation. This reduces the importance of inertial forces. Characteristic impedance ( $Z_c$ ) reflects the interplay between these inertial effects and the local storage of blood in the proximal aorta and the load initially experienced by the ventricle upon opening of the aortic valve. It is calculated by plotting the relation of time-varying  $P_{ao}$  (aortic pressure) vs. time-varying  $F_{ao}$  (aortic flow) during the ejection phase of the cardiac cycle; the slope provides  $Z_c$  [in mmHg/(mL/s)]. This parameter is dependent on blood pressure and aortic size; a stiff and narrow aorta leads to high  $Z_c$ , a distensible, wide aorta to a low  $Z_c$ . While  $Z_c$  determines the upstroke of pressure, pulse pressure is mainly determined by the total arterial compliance (TAC) of the arterial tree in combination with the systemic vascular resistance (SVR). The simplest approximation of TAC is the ratio of the stroke volume and pulse pressure (mL/mmHg), although this leads to systematic overestimation. TAC is highly size-dependent, depends non-linearly on arterial pressure, and that there are systematic differences between different methods, making TAC a parameter difficult to standardize (Figure 11).

#### Arterial afterload: pulse wave velocity and wave reflection

The above section simplifies the arterial system to a simple 'windkessel' system. Cardiac contraction gives rise to pressure- and flow waves travelling through the arterial tree. The stiffer the arteries, the higher the pulse wave velocity (PWV; Figure 12). PWV is proportional to the intrinsic mechanical properties of the arterial wall (stress–strain relationships), the ratio of wall thickness to lumen diameter, and inversely proportional to the density of blood (which is virtually constant). Thus, PWV is independent of size and only varies with arterial remodelling or changes in arterial tissue properties (note that these are pressure-dependent). The carotid and femoral artery is the most commonly used measuring locations, with time delay derived from either pressure (tonometry), ultrasound- (pulsed Doppler), or CMR-based (phase contrast) signals. As the carotid and femoral artery is not along a single unequivocal trajectory, the latest consensus is that distance is approximated as 0.8 times the linear distance measured directly between the carotid and femoral sites. Age-specific normal values for carotid–femoral have been reported (Figure 13), but have the disadvantage of obscuring the important effect of age.<sup>81</sup> Numerous studies have now demonstrated an association between increased arterial stiffness and increased cardiovascular risk. Although PWV provides an overall estimate of the elastic properties of the aorta and central arteries, it also depends on functional and dynamic properties, including production of nitric oxide. It is also possible to assess the local elastic properties at the carotid or femoral artery, and several ultrasound-based techniques exist for this purpose (e.g. wall tracking to measure arterial distension) or are under investigation (pulse wave imaging and shear wave imaging).

Wave dynamics are too complex to resolve in full detail in an *in vivo* setting and are commonly simplified, considering only one forward (generated by the heart) and one backward wave (due to reflections

Hemodynamic Parameter	Anatomic Structure (Functional and structural correlate)
Systemic Vascular Resistance	Arterioles (arteriolar “tone” / diameter)
Total arterial Compliance	Large arteries, and to a lesser extent muscular arteries and small vessels (size and stiffness).
Characteristic Impedance ( $Z_c$ )	Proximal Aorta (size and stiffness)
Wave reflection magnitude	Muscular arteries, resistance arterioles (impedance mismatch between proximal and distal arterial segments).
Wave reflection timing	Aorta (pulse wave velocity) and reflection sites (muscular arteries, arterioles).

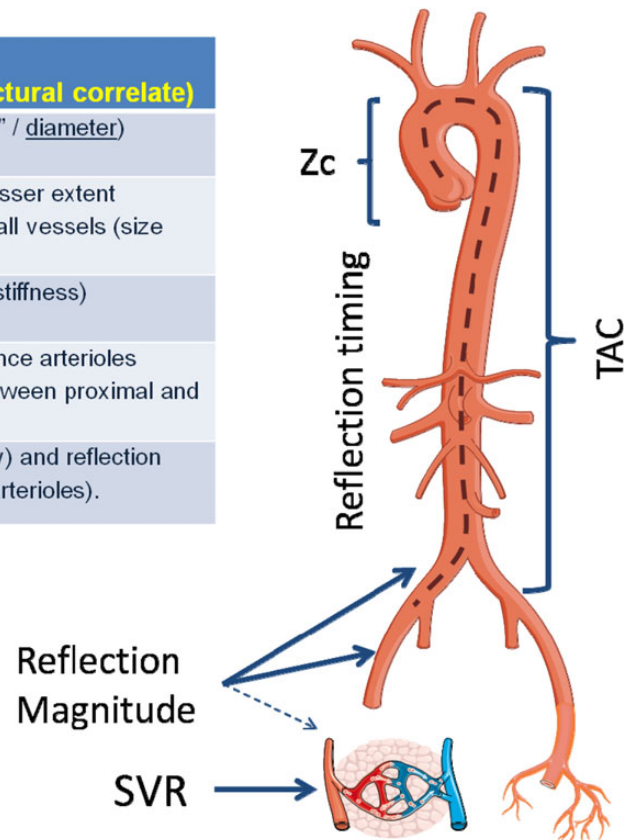
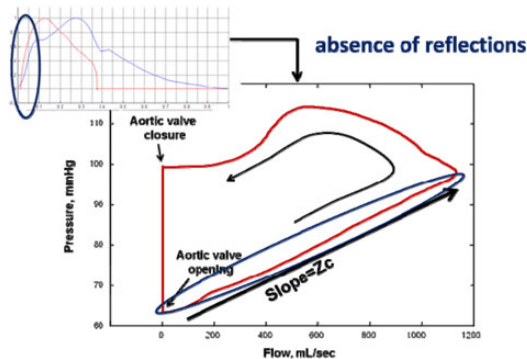

**Figure 11** Overview of all components of arterial afterload. The table summarizes the contributors to the haemodynamic parameters and the schematic figure on the right emphasizes the roles of impedance and reflection. The graphic at the bottom left summarizes the assessment of characteristic impedance from measured aortic pressure and flow waveforms. SVR: systemic vascular resistance; TAC: total arterial compliance.

in the periphery). The timing and magnitude of these waves can directly be linked to cardiovascular pathophysiology. Recent studies have reported an association between augmentation index (a rather poor measure of wave reflection) and cardiovascular risk,<sup>82</sup> although there is disagreement about the prognostic value of this information. An increased magnitude of wave reflection, measured with the wave decomposition technique, is an independent prognostic determinant of cardiovascular risk and a powerful and independent predictor of incident heart failure.<sup>83</sup>

## Ventriculo-arterial interaction

### The classical approach to ventriculo-arterial matching

The most widespread paradigm for the assessment of ventricular–vascular coupling is the ventricular ( $E_{es}$ )–arterial ( $E_a$ ) elastance framework, which links mechanical performance of the ventricle to its oxygen consumption.

For an efficient energy transfer, the LV should develop an elastance that is greater than the arterial elastance. Arterial elastance is commonly calculated as end-systolic pressure/stroke volume and is a measure of resistive, not pulsatile load.  $E_{es}$  is the end-systolic elastance (slope of the end-systolic pressure–volume relation), a

measure of ventricular contractility.  $E_a$  stands for arterial elastance (ratio of end-systolic pressure and stroke volume), although it is an imperfect measure of arterial properties, being highly sensitive to the heart rate. Resting  $E_a/E_{es}$  ratios of  $\sim 0.62$ – $0.82$  are observed across species and in human populations. The LV generates maximal stroke work when  $E_a/E_{es} = 0.80$ , while it operates at maximal energetic efficiency with an  $E_a/E_{es}$  of  $0.70$ .<sup>84</sup> The normal  $E_a/E_{es}$  values seen in the Asklepios cohort<sup>85</sup> and the Olmsted cohort<sup>86</sup> suggest that normal subjects'  $E_a/E_{es}$  values approximate this optimal value. Values  $>1$  indicate an ‘ill-matched’ ventricle and arterial system. While the framework is essentially based on pressure–volume loop analysis—and hence restricted to an invasive setting—it has been simplified to make it suitable for application in clinical settings, approximating  $E_{es}$  as the ratio of end-systolic pressure and the end-systolic volume (ESV) or via the use of single-beat methods that take advantage of the relatively small variability in the shape of the normalized time-varying left ventricular elastance curve over the cardiac cycle.<sup>87,88</sup>

### Novel approaches to ventriculo-arterial matching

The standard  $E_a/E_{es}$  analysis does not involve any evaluation of time in the analysis. Using cardiac ultrasound and applanation tonometry (Figure 13), myocardial stress can be expressed as a function of time

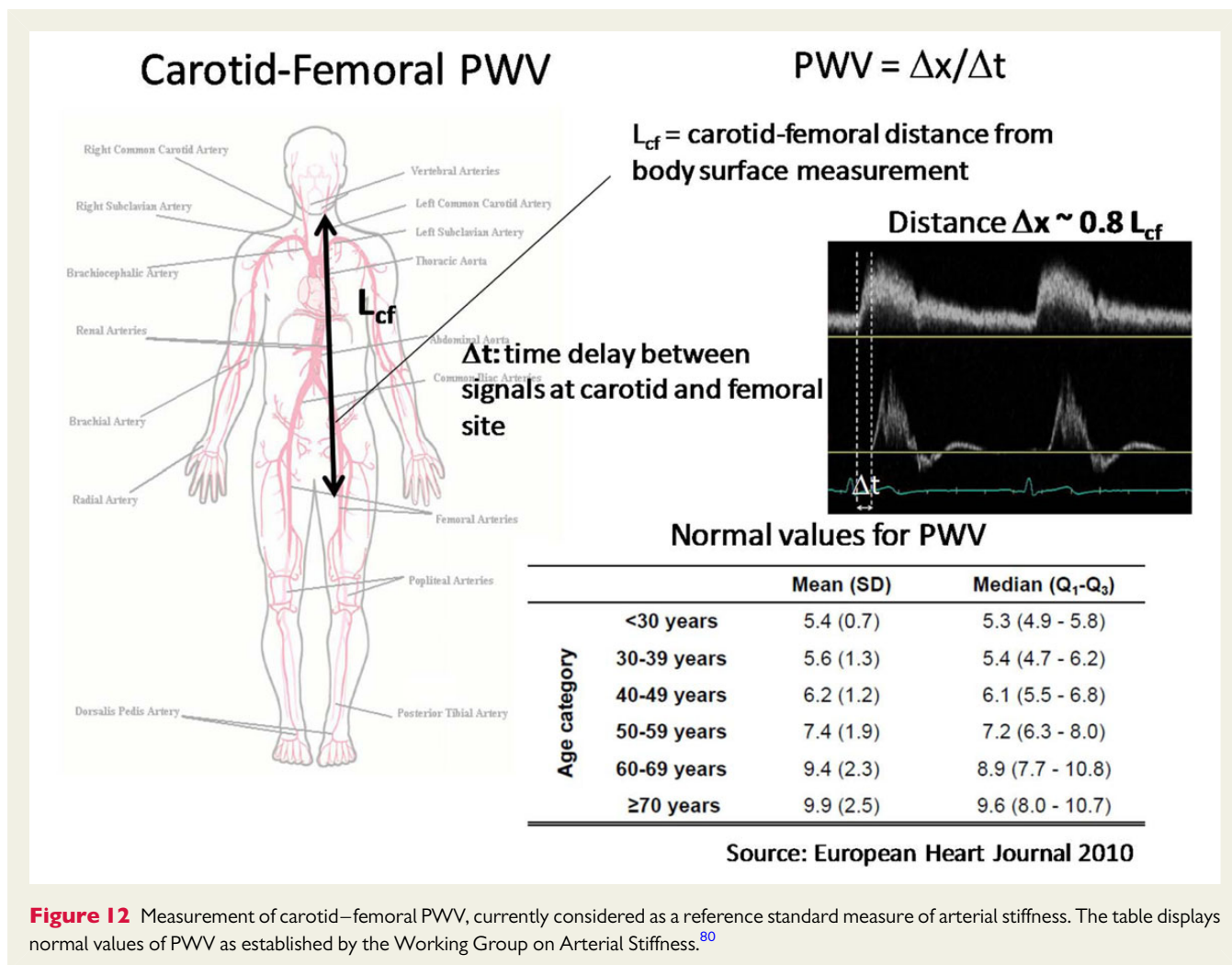

**Figure 12** Measurement of carotid–femoral PWV, currently considered as a reference standard measure of arterial stiffness. The table displays normal values of PWV as established by the Working Group on Arterial Stiffness.<sup>80</sup>

throughout systole.<sup>89</sup> Peak stress occurs in early systole, before important contributions of reflected waves to central pressure and correlates directly with SVR and Zc.<sup>80</sup> The greater peak and end-systolic wall stress and higher ejection phase stress-time integral in women may relate to the susceptibility of women to heart failure.<sup>80</sup>

Wave intensity analysis is a new method of assessing ventriculo-vascular interaction. There are three aortic waves: (i) a wave reflecting LV contraction, generating a forward wave increasing pressure and flow; (ii) a reflected wave, generally increasing pressure and lowering blood flow, and (iii) a late-systolic wave due to LV relaxation, lowering blood pressure and flow. Current research is seeking whether this wave-based analysis can be used to quantify cardiac systolic and diastolic performance.

### Assessment of the aorta

Hypertension is an important contributor to aortic disease, and any echocardiogram performed for the evaluation of end-organ disease should include assessment of the aorta. Echocardiographic views are usually limited to the ascending aorta between the coronary sinuses and main pulmonary artery, the aortic arch (in the suprasternal view), the descending aorta in the far-field of the parasternal, suprasternal, and foreshortened apical two-chamber view, and the abdominal aorta in the subcostal view. In particular, this simple step

adds an incremental value in screening men >65–70 years old for abdominal aortic aneurysm, especially if they are smokers. Coarctation of the aorta is a well-known structural abnormality that can lead to hypertension and LV hypertrophy and may go undetected by clinical assessment, particularly in younger adults. The echocardiogram is central to making this diagnosis, so younger patients presenting with hypertension should undergo 2D imaging, colour and Doppler assessment of the distal arch and upper descending aorta. Further information about echocardiography and aortic disease, including normal aortic dimensions, are described in the EACVI recommendations for clinical practice.<sup>90</sup>

### Recommendations

- Blood pressure should be obtained at the time of the examination and integrated into the report.
- Aortic dimensions should be reported in all studies of hypertensive subjects.
- Measurement of pulse wave velocity should be considered as a marker of vascular health and risk in primary prevention patients.
- Assessment of ventriculo-arterial mismatch is currently a research rather than a routine clinical investigation.

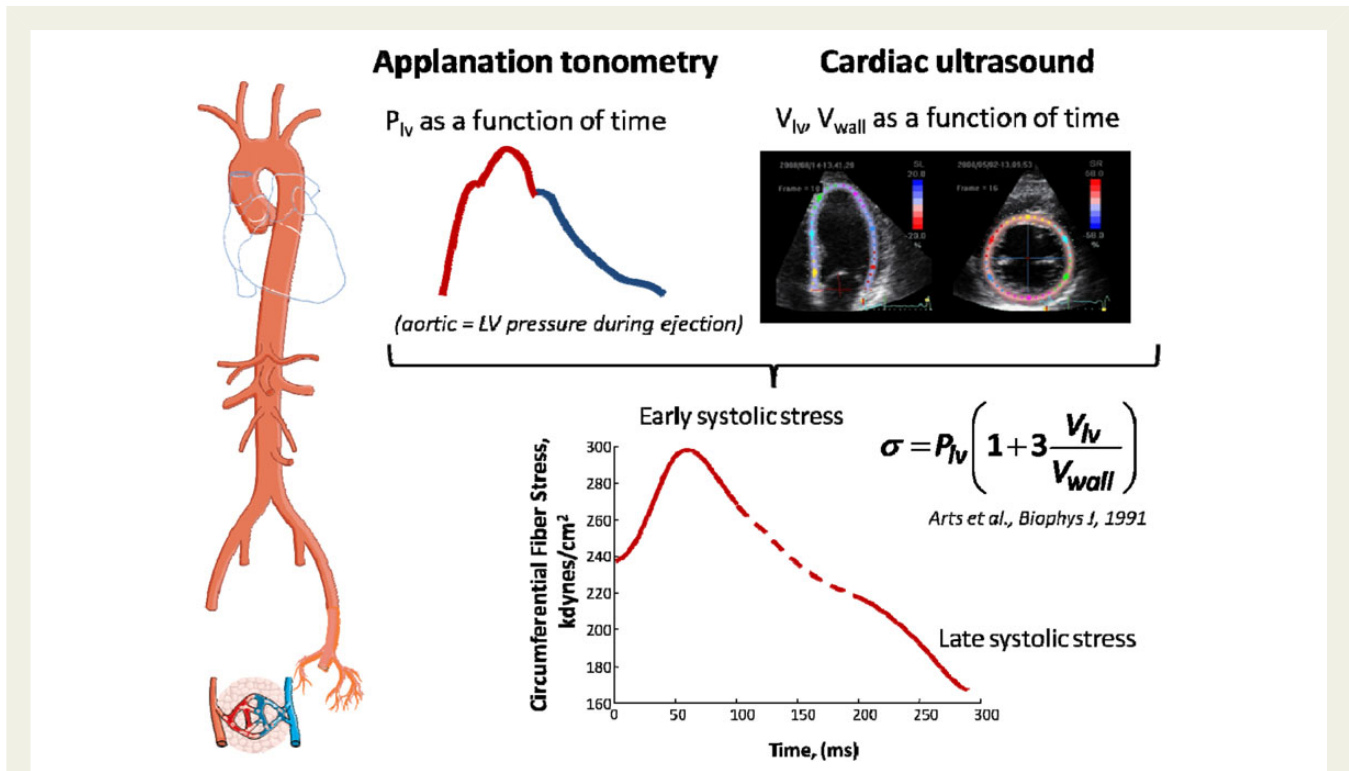

**Figure 13** Assessment of time-varying myocardial stress using applanation tonometry and cardiac ultrasound. Myocardial stress peaks in early systole. Late-systolic stress is significantly reduced due to the decrease in LV cavity volume throughout systole. The dotted line represents the middle third of ejection.

## LV systolic function in hypertension

### Parameters from linear measurements

LV linear dimensions for the calculation of LVM are widely used in the setting of hypertensive patients. The use of these measurements for the evaluation of endocardial fractional shortening (FS) has been superseded by more accurate and reliable measures. Likewise, the Teichholz or Quinones methods for measurement of EF from linear measurements are dependent on geometric assumptions and are not recommended.

### Two-dimensional measurements

While the process of tracing LVM (above) and volumes are similar, the prognostic independence of LVM and function justifies their separation. The techniques and reference normal values for obtaining EF from tomographic 2D echocardiography are summarized in the Chamber Quantification update.<sup>29</sup> The biplane method of discs (modified Simpson's rule obtained from apical four- and two-chamber views) is the most accurate in abnormally shaped ventricles.<sup>46,91</sup>

In the pre-harmonic and pre-digital era, the main sources of interstudy variability included repeated echo recordings, repeated video measurements, and measurements made by different investigators.<sup>92</sup> Similar analyses have not been performed by harmonic imaging, which may be an important distinction for two reasons. The use of lower frequencies (required for the creation of a wider broadband) implies a reduction of spatial resolution, with apparently thicker structures and potential effects on the measurement of wall

thickness. On the other hand, the use of harmonic imaging improves the reproducibility of 2D LV volumes.<sup>93</sup> When compared with CMR, 2D determination of LV volumes shows higher interstudy variability which reaches statistical significance for LV ESV (4.4–9.2% vs. 13.7–20.3%,  $P < 0.001$ ),<sup>94</sup> and results in higher calculated sample sizes (increases of 55–93% in comparison with CMR) to show clinically relevant changes in LV size.

The ejection phase indices (FS, EF, stroke volume, and cardiac output) cannot determine the relative contribution of each of these variables to LV pump function. In particular, load dependency of these parameters may induce inaccurate estimation of intrinsic myocardial contractility in chronic pressure overload conditions. The estimation of LV afterload may help in determining whether or not observed LV pump function is representative of actual myocardial contractile performance. The most direct measurement of LV afterload is end-systolic stress (ESS).<sup>95</sup> Two main types of ESS can be measured, meridional and circumferential ESS (cESS), each acting as counter forces to fibre shortening.<sup>95</sup> Longitudinal shortening of endocardial fibres is limited by longitudinal (meridional) ESS, which can be measured using a catheterization-validated formula which incorporates end-systolic LV internal diameter (LVIDs) and wall thickness coupled with simultaneous cuff blood pressure.<sup>36</sup>

### Three-dimensional measurements

Assessment of LV volumes by 2DE is limited by foreshortening, malrotation, angulation, and a reliance on geometric assumptions for volumetric calculation, resulting in an underestimation of the true



volumes, particularly in remodelled ventricles.<sup>96,97</sup> Transthoracic 3DE provides a rapid and accurate method for quantifying LV volumes and EF (LVEF).<sup>98,99</sup> It has a superior reproducibility to 2DE, with a closer correlation to CMR-derived volumes.<sup>50,96</sup> For these reasons, the ASE and EACVI recently recommended 3DE, rather than 2DE, for the routine assessment of LV volumes and EF.<sup>100</sup>

Two recent studies have addressed normal ranges of 3D measurements but identified somewhat different normal values, emphasizing racial, gender, and age differences.<sup>49,101</sup>

A recent meta-analysis of validation studies comparing 3DE and CMR demonstrated that considerable variability still exists in the measurement of LV volumes ( $\pm 34$  mL for EDV,  $\pm 30$  mL for ESV, and  $\pm 12\%$  for EF), although it is less than that observed between 2DE and CMR.<sup>97</sup> Moreover, both 2DE- and 3DE-derived volumes are less accurate in dilated LVs.<sup>102</sup> Several sources of 3D volume acquisition and measurement error are discussed in the recent ASE/EACVI guidelines, including difficulty in imaging the anterior and lateral walls because of interference from ribs, low line density (and therefore lower spatial resolution—which may be partly addressed with the use of LV opacification), low temporal resolution (which may be addressed by using multiple subvolumes—but at the risk of stitching artefacts), and time-consuming off-line analysis.<sup>100</sup> Recently, a fully automated endocardial contouring system combined with real-time full-volume 3DE has been described as providing accurate and reproducible volumes.<sup>103</sup>

## Midwall function

### Rationale

LV systolic function is commonly assessed through the use of EF and FS. However, because these measurements are performed at the endocardial surface, their appropriateness has been questioned in patients with LV hypertrophy. The inner layer of the LV has been shown to move inward further than the outer layer, a difference markedly increased in hypertrophic walls due to the 'cross-fibre shortening' phenomenon which, in hypertrophic LVs, achieves normal systolic wall thickening despite reduced shortening of individual myocardial segments.<sup>104–106</sup> Hence, LVEF and FS often lead to overestimation of LV systolic performance yielding normal or even supranormal results not matching the individual's clinical situation and prognosis, since they take into account geometric changes that do not accurately reflect the actual contractile function of the myocardium.<sup>104,107–109</sup> The greatest proportion of ventricular myocardial fibres is located in the myocardial midwall, the region responsible for circumferential left ventricular contraction and where cross-fibre shortening is less significant.<sup>110–112</sup> Consequently, indices representing LV midwall mechanics have received increasing attention lately, as they have shown to better reflect myocardial contractile status in patients with LV hypertrophy.<sup>109,113,114</sup>

A variety of parameters have been used to assess LV midwall function. Midwall FS (FS<sub>mw</sub>) has been the most widely used. Based on M-mode measurements, calculation of FS<sub>mw</sub> is generally calculated following the model described by Shimizu *et al.*,<sup>104,115</sup> based on the assumption of a cylindrical-shaped LV resulting from the union of two concentric cylindrical shells of equal end-diastolic thickness and on the fact that LVM does not vary throughout the cardiac cycle. This model allows FS<sub>mw</sub> to be calculated through the following formula:  $FS_{mw} = \{(LVIDd + IVSd/2 + PWD/2) - (LVIDs + Hs/2)\} /$

$LVIDd + IVSd/2 + PWD/2)$ , where Hs is the systolic thickness of the shell. To eliminate the effects of LV afterload on FS<sub>mw</sub>, stress-corrected FS<sub>mw</sub> is calculated through the following formula:  $cESS = \{[SBP \times (LVIDs/2)^2] \times [1 + (LVIDs/2 + LV - PWs)/2 / (LVIDs/2 + LV - PWs/2)]\} / \{(LVIDs/2 + LV - PWs)^2 - (LVIDs/2)^2\}$ , where SBP represents systolic blood pressure.<sup>109</sup> This correction has shown to discriminate hypertensive from physiological LV hypertrophy in athletes.

### Validation and normal values

Several studies have provided a reference of normal absolute and stress-corrected FS<sub>mw</sub> values in healthy populations.<sup>109,116–120</sup> Mean normal values in these studies range from 17 to 21%, with no observed differences with gender and ethnicity, and while most studies have pointed out a slight decrease in FS<sub>mw</sub> with age, these may be due to subclinical conditions and have shown no statistical significance in some series in which the study population was screened to rule out cardiovascular disease.<sup>119</sup>

The study of midwall mechanics has shown to be superior to other conventional echocardiographic indices of LV systolic function in several clinical scenarios, through better prediction of cardiovascular outcomes than indices based on endocardial measurements and better correlation with patients' clinical status.<sup>120–123</sup>

### Limitations

Some of the limitations of midwall function assessment include the fact that FS<sub>mw</sub> is based on a limited region of the LV, which could hinder its application to patients with variable LV geometries.<sup>124</sup> Another potential limitation is the need for manual tracking, which introduces the problems of time-consuming analysis and potential interobserver variability. However, new indices and calculations partly overcome these limitations through the analysis of 2D and 3D midwall mechanics, introducing the concepts of 2D and 3D midwall EF.<sup>125,126</sup> Finally, advanced echocardiographic techniques are modifying the understanding of the hypertensive heart. Disturbances of longitudinal strain of the endocardial layer precedes the alteration of circumferential strain, which is attributed to the midwall layer.<sup>127</sup> This is important because LV longitudinal dysfunction plays a role in mediating the effect of LV geometry on LV diastolic impairment.<sup>116</sup>

## Tissue Doppler assessment of systolic function

Tissue Doppler was the first widely available myocardial imaging technique, and is credited with improving the feasibility of longitudinal ventricular function measurement. Several studies have shown tissue Doppler—using either pulsed-wave or colour mapping—to be a reliable tool for the assessment of LV systolic function. This method has been validated against other methods for the assessment of myocardial systolic performance and regional coronary blood flow, as well as with histological findings.<sup>128–131</sup> Its high temporal resolution enables accurate determination of myocardial velocity and acceleration even when overall image quality is deficient and endocardial delineation is poor.<sup>132,133</sup> Technical considerations related to tissue Doppler have been considered in depth in an ASE/EAE consensus statement, and will not be replicated here.<sup>134</sup> In hypertensive heart disease, the tissue relaxation velocity ( $e'$ ) is

reduced compared with normal, but to a much lesser degree than it is in other hypertrophic situations such as hypertrophic cardiomyopathy and infiltrative disorders such as amyloidosis.

To obtain a reliable signal, the tissue Doppler sample volume should be placed at the edge of the mitral annulus, trying to maintain the volume line in the direction of the mitral annulus excursion to avoid velocity underestimation or missing information on tissue motion. The recommended Doppler velocity range is usually  $\pm 15$ – $20$  cm/s, but can be adjusted to the lowest possible without generating aliasing. The main parameter for systolic performance that can be extracted from tissue Doppler evaluation is  $s'$ , which can be identified as a wave signal in the direction of the apex and initiated immediately after the QRS complex. Among tissue Doppler parameters,  $s'$  has shown the best correlation with LVEF and significant clinical outcomes such as rehospitalization and reduced survival<sup>130,135</sup>, although measurements at the septal and lateral side in the apical four-chamber view have proved to produce good results ( $s' < 7$  cm/s showing 93% sensitivity and 87% specificity to identify patients with LVEF  $< 45\%$ ). Other authors have reported slightly higher diagnostic power with measurements at six sites from the apical four-chamber, two-chamber and long-axis views (six-site average  $s' > 5.4$  cm/s showing 88% sensitivity and 97% specificity for LVEF  $> 50\%$ ).<sup>128,130</sup>

In the setting of hypertensive patients, tissue Doppler measured  $s'$  helps differentiate physiological LVH in athletes from hypertrophic cardiomyopathy, and the latter from LVH secondary to hypertension. Four-site measured mean  $s' < 9$  cm/s has shown to discriminate physiological from pathological LVH with a sensitivity of 87% and a specificity of 97%.<sup>136</sup> Other studies have pointed out that hypertrophic cardiomyopathy patients have lower  $s'$  values and higher heterogeneity than hypertensive LVH.<sup>137</sup>

It is important to note that tissue Doppler relies completely on the detection of motion. This needs to be taken into consideration, since a potential limitation of this tool is the detection of myocardial motion occurring due to passive movement, such as swinging or tethering motion, instead of active myocardial contraction, potentially leading to either an over- or underestimation of LV systolic function. In addition, the use of deformation imaging in hypertensive heart disease has moved attention from midwall to longitudinal (and hence subendocardial) function. Impairment of longitudinal function always precedes the depression of LVEF in hypertensive patients, and may be a guide to the presence of fibrosis. Finally, tissue Doppler parameters are influenced by age and sex.<sup>138</sup>

## Assessment of myocardial function by strain

Strain, strain-rate, and twist imaging (deformation imaging) are relatively recent non-invasive methods for the assessment of regional and global myocardial function, allowing discrimination between active and passive myocardial tissue movement.<sup>139</sup> Assessment of strain and twist is extracted from images using the commercially available software, providing sensitive echocardiographic measures to detect early subclinical evidence of ventricular dysfunction. This information can be gathered using tissue Doppler echocardiography or speckle tracking,<sup>140</sup> and has been described in detail in a recent

ASE/EACVI Consensus Statement.<sup>134</sup> The measurement of strain has been well validated with sonomicrometry,<sup>141</sup> three-dimensional tagged CMR,<sup>142</sup> and cyclically compressed tissue-mimicking gelatin phantom.<sup>143</sup> Among the different deformation (strain) components, longitudinal strain has gained an important value in this context. Longitudinal strain corresponds to the function of the endocardial layer of myocardium, where longitudinal fibres are subjected to the negative impact of early development of fibrosis in hypertensive heart disease.<sup>144</sup> However, strain is highly sensitive to increased afterload, and the relative degree of impairment of strain that is due to LV dysfunction vs. that is due to hypertension may be difficult to tease apart. Reported normal values of global longitudinal strain vary from  $-15.9$  to  $-22.1\%$  (mean,  $-19.7\%$ ; 95% CI  $-20.4$  to  $-18.9\%$ ).<sup>145</sup>

This technique has been used to differentiate between different causes of increased wall thickness. In addition to the degree of reduction of strain, the pattern of strain reduction is also important. For example, amyloidosis is characterized by a particular pattern of apical sparing not seen in other causes of hypertrophy,<sup>146</sup> and hypertrophic cardiomyopathy is associated with deformation disturbances at the site of hypertrophy with less abnormal deformation elsewhere. The morphology of the longitudinal strain signal may also be important in recognizing myocardial scarring. A characteristic double peak in the strain-rate signal has been identified in patients with scar tissue associated with hypertrophy in hypertrophic cardiomyopathy, Fabry's disease, and aortic stenosis.<sup>147</sup> This phenomenon presumably reflects a degree of post-systolic shortening in the presence of fibrosis. Thus, although the functional markers are non-specific for the diagnosis of hypertensive heart disease, they may demonstrate specific patterns and degrees of disturbance that distinguish between hypertensive hypertrophy and other aetiologies, as well as recognizing the contribution of fibrosis. Longitudinal strain can be even used to differentiate hypertensive heart disease from functional myocardial changes in the athlete's heart.<sup>127</sup>

Finally, CMR may be used for quantifying myocardial function, using techniques that measure myocardial deformation. It is not clear that these are superior to the echo techniques, as they are obtained at lower temporal resolution. This may be particularly pertinent for the identification of post-systolic shortening or disturbances of diastolic function.

## Prognostic significance of LV function in hypertension

### Chamber function

The prognostic significance of LV function is well established. It is known that heart failure is a common consequence of hypertension and in the majority of patients is related to impaired LV systolic function, which accounts for about half of heart failure cases.<sup>148,149</sup> However, hypertension is not necessarily associated with a reduced systolic function—this may be increased in the initial stages.<sup>150</sup> EF, a global measure of LV chamber function, is used to distinguish systolic (EF  $< 50\%$ ) from diastolic HF (EF  $\geq 50\%$ ), and is a reliable method for predicting primary cardiac events and cardiac mortality in individuals. Endocardial FS is a good measure of LV global systolic function; however, its use in the setting of hypertension is discouraged, especially in the presence of LV hypertrophy. As discussed above, both EF and FS are constrained

because they measure endocardial function, whereas the true parameter of interest is midwall function. In addition, the limited field of view with M-mode leads to an under-appreciation of regional wall motion. Wall motion abnormalities can identify adults without known cardiovascular disease (CVD) who are at 2.4- to 3.4-fold higher risk of CVD morbidity and mortality.<sup>151</sup>

In contrast, 2D strain has been shown to be abnormal in hypertensive patients with normal EF,<sup>127</sup> as well as in prehypertension.<sup>152</sup> Although EF is accepted as a prognostic marker, its prognostic value in the range that is close to normal is limited. Strain does not seem to share this limitation,<sup>66</sup> and this may be of value in discerning the progression from hypertensive heart disease to heart failure.

### LV midwall function in hypertension

The calculation of LV midwall shortening ( $FS_{MW}$ ) has been discussed above. Depressed FS is associated with increased LV RWT and LVM, and FS may be impaired in hypertensive patients with normal LVEF.<sup>153</sup> FS predicts adverse outcomes,<sup>108</sup> but there are limited data about the relative ability of FS to predict cardiovascular events independent of known established risk factors (LVM and BP).<sup>122</sup> Indeed, some authorities question the incremental information provided by the assessment of LV systolic function to LVM in hypertensive heart disease.<sup>154</sup> Nor has it been shown that improved treatment of LV chamber systolic function (in those with a normal EF and depressed LV  $FS_{MW}$ ) is associated with lower CVD morbidity and mortality, independent of change in BP and LVM in treated hypertensive patients.<sup>122</sup>

#### Recommendations

Assessment of LV function provides incremental information to the assessment of LVM in hypertensive subjects and should be a component of the echo report in all hypertensive patients. LVEF remains the most widely reported measure of global LV function. Global longitudinal strain has shown a prognostic value in patients with near-normal EF, where the prognostic information from EF is less useful.

## Diastolic function in hypertension

### Assessment of mitral inflow

#### Acquisition and measurements

Previous position statements have provided guidance on the technical requirements for diastolic function evaluation,<sup>155</sup> including sample volume size and location, sweep speed, and respiratory phase. Mitral inflow measurements should include early peak filling ( $E$  velocity), late peak atrial filling ( $A$  velocity),  $E/A$  ratio, deceleration time (DT) of  $E$  velocity, and isovolumic relaxation time (IVRT).

#### Normal values

Normal values are reported in Table 7. Diastolic filling patterns are classified by the combined quantitative analysis of  $E/A$  ratio, DT, tissue Doppler, and LA volume in particular.<sup>156</sup> With increasing age, impairment of LV relaxation leads to low  $E$  velocity, high  $A$

velocity, and decreased  $E/A$  ratio with prolongation of DT.<sup>157</sup> Delayed relaxation occurs in uncomplicated systemic arterial hypertension. Because of the load dependence of these measurements, the pseudonormal filling pattern cannot be recognized on the basis of simple evaluation of mitral inflow pattern, but needs additional assessment during a Valsalva manoeuvre (low reliability) or the additional assessment of pulmonary venous flow (intermediate reliability) or pulsed Tissue Doppler-derived  $e'$  velocity of the mitral annulus (highest reliability). The detection of LA enlargement is a marker of longstanding increase of LA pressure in hypertensive heart disease.

#### Prognostic significance of mitral inflow patterns

The main prognostic importance of Doppler-derived LV filling is in patients with systolic HF, where mitral inflow measurements correlate with LV filling pressure, functional classes, and prognosis.<sup>158</sup> In hypertension, normal in-treatment transmitral flow pattern indicates a low risk for heart failure (HR 0.22 [95% CI 0.05–0.98,  $P = 0.048$ ], independent of blood pressure.<sup>159</sup> However, the intermediate ranges of  $E/A$  ratio (from 0.6 to 1.5) do not stratify prognosis in hypertensive subjects,<sup>17</sup> probably because normal and pseudonormal patterns are combined. Although antihypertensive treatment in patients with LVH results in improvement of mitral inflow patterns, this was not associated with reduced cardiovascular morbidity and mortality.<sup>159</sup>

### Tissue Doppler assessment of myocardial diastolic function

#### Acquisition and measurements

Guidance on the technical requirements for tissue Doppler acquisition has been provided regarding sample volume location, angulation, and respiratory phase.<sup>160</sup> In hypertensive heart disease, early diastolic tissue velocity ( $e'$ ) is reduced by reduction in LV relaxation. However, it is also influenced by preload, systolic function, and LV minimal pressure. The other basic measured parameter is late (atrial) diastolic velocity ( $a'$ , influenced by LA function and LV end diastolic pressure).  $E/e'$  has been used as a measure of LA driving pressure or LV filling pressure.<sup>161</sup> However, there are a number of situations where  $e'$  and  $E/e'$  may be misleading,<sup>162</sup> including reduced septal  $e'$  velocity due to inferior infarction or annular calcification, and increased transmitral  $E$  velocity due to mitral regurgitation. Averaging septal and lateral  $e'$  may reduce some of this variability, but does not address all of the limitations of the parameter.

#### Normal values

Similar to mitral inflow velocity,  $e'$  values diminish with age (Table 7). For the evaluation of LV global diastolic function, it is recommended to record and measure tissue Doppler signals at both septal and lateral mitral annulus and obtain their average.<sup>156</sup> The rationale of averaging septal and lateral values is derived from the observation that  $e'$  velocities are significantly greater at the lateral location than at the septal placement of the annulus. While single-site measurements can be used in the presence of globally normal or abnormal LV systolic function, the average of the two site measurements is particularly important in patients with LV regional dysfunction.

**Table 7** Normal Doppler values for diastolic measurements (modified from Nagueh et al.<sup>156</sup>)

Measurement	Age group (years)			
	16–20	21–40	41–60	>60
IVRT (ms)	<32, >68	<51, >83	<60, >88	<73, >101
E/A ratio	<0.98, >2.78	<0.73, >2.33	<0.78, >1.78	<0.6, >1.32
DT (ms)	<104, >180	<138, >194	<143, >219	<142, >258
Septal e' (cm/s)	<10.1	<10.1	<7.6	<6.2
Lateral e' (cm/s)	<13	<14	<11.5	<5.9

For septal  $E/e'$ , values of  $<8$  can be considered normal and  $>15$  are elevated, with 8–15 being ambiguous.

## Prognostic significance of tissue Doppler parameters

Annular tissue velocities are strong predictors of outcome in a variety of settings. In a 2-year follow-up study of  $>500$  patients, 35% of whom had hypertension, Wang et al.<sup>163</sup> showed that a pulsed-wave  $e'$  of  $<3$  cm/s was associated with a 5.3-fold increment of hazard. As these data were gathered from colour-coded tissue Doppler, they represent unusually low values for  $e'$  velocity, analogous to pulsed-wave signals in the range of  $<5$  cm/s. Similar findings have been described using an  $e'$  of  $<3.5$  cm/s in hypertension and LV hypertrophy.<sup>164</sup> It has to be acknowledged, however, that velocities  $<5$  cm/s are quite extreme, and less usual in hypertensive heart disease than hypertrophic cardiomyopathy or infiltration.

Likewise,  $E/e'$  has prognostic implications, with  $E/e' \geq 15$  having been shown to add an independent prognostic value to B-type natriuretic peptide and EF.<sup>165</sup> Although studies have been more focused on post-MI and heart failure than hypertension, Sharp et al.<sup>166</sup> recently demonstrated the prognostic value of  $E/e'$  ratio in uncomplicated hypertensive patients, independent of LVM. On these grounds, the 2013 ESC/ESH guidelines on arterial hypertension promote the use of  $E/e'$  in the detection of cardiac target organ damage in hypertensive heart disease.<sup>167</sup>

### Recommendations

All echocardiography reports in patients with hypertension should include specific comments about diastolic function grade, left atrial volume, and about normal vs. elevated LV filling pressure (usually based on  $E/e'$ ).

## Cardiac impact of hypertension treatment

### LV hypertrophy regression

LV hypertrophy represents an important end-organ consequence of hypertension. Population-based studies using echocardiography have demonstrated hypertrophy to be closely linked with adverse events,<sup>42,107</sup> including stroke, renal impairment, left ventricular dysfunction, atrial and ventricular arrhythmias, and sudden cardiac arrhythmia or premature death.<sup>168</sup> The eventual development of

complications from LVH represents long-term effects that are too final to guide clinical therapy, and too slow as a research outcome. Therefore, LVH has been proposed as a surrogate marker of outcome. LVH has been shown to be reversed or prevented by a variety of haemodynamic, non-haemodynamic, and pharmacological factors.<sup>169</sup>

Nonetheless, the use of repeat imaging to document changes in LVM has been difficult to incorporate into standard practice for at least two reasons. The first relates to the inherent variability of LVM measurements with echocardiography. While reductions in the ventricular mass have been associated with improved outcome across populations, in studies which identify regression of hypertrophy on an individual basis, large populations are required to overcome the variability of these measurements. Thus, while the association between LVH regression and improved outcome has now been recognized in a number of studies,<sup>170</sup> because of the test–retest limitations of echocardiography, CMR may be more accurate to demonstrate this effect.<sup>94</sup> This role of echocardiography may be improved by the enhancement and clinical use of 3DE, which has been validated against CMR.<sup>53</sup>

The second limitation is that hypertrophy occurs in 36–41% of hypertensive subjects,<sup>171</sup> but hypertension is not the only cause of this problem. Hypertrophy may be influenced by obesity, diabetes, the metabolic syndrome, and renal impairment, among other aetiologies. Progression of the condition may lead to ischaemia, both due to concurrent coronary artery disease as well as failure of vascular proliferation to match myocardial proliferation, vascular compression, and the effect of raised LV pressure on subendocardial flow.

### Change in LV geometry

Changes in LV geometry have been associated with improved blood pressure control, reflecting the impact of afterload on LV remodelling. Again, however, the variability of 2DE has been a limitation in understanding the association of reverse remodelling with improved survival, using conventional techniques. Recent evidence has indicated that use of CMR (or potentially 3DE) provides a means of measuring sphericity on a serial basis, and therefore documents remodelling changes in response to blood pressure control.

### Change in systolic function

LV systolic function, measured by EF, is normally preserved until late in the course of hypertensive heart disease. Indeed, although EF is associated with outcome in patients with moderate LV impairment,

the association of mild or borderline impairment with adverse outcome has been more difficult to show. Likewise, volumetric and EF changes in heart failure have been associated with improvements in outcome,<sup>172,173</sup> but this information is difficult to apply to hypertensive heart disease in which EF is either preserved or borderline reduced.

## Change in diastolic function

Diastolic dysfunction, particularly in the later stages of hypertensive heart disease, is associated with prognosis.<sup>174</sup> However, most patients with hypertensive heart disease have grade I diastolic dysfunction, and changes in this finding are intrinsically ambiguous. When the *E/A* ratio is  $<1$  and moves towards unity, this may occur because of recovery of function and improvement in LV suction, or it may occur because of raised filling pressures and transition of grade I to grade II disease. Documentation of changes in diastolic function is difficult to interpret in any patient, and no less in those with hypertensive heart disease. In a randomized study of angiotensin receptor blockade, no significant change in *e'* was witnessed between valsartan and the control group.<sup>175</sup> Nonetheless, other studies have shown that improvements in LV geometry after treatment in hypertensive patients with ECG evidence of LV hypertrophy have been associated with parallel improvements in Doppler-derived indices of diastolic function.<sup>176</sup>

### Recommendations

While echocardiography has been key in demonstrating the beneficial effects of hypertension treatment in large cohort studies, routine reassessment of echocardiograms to examine treatment response in hypertensive subjects is not recommended, due to the limited reproducibility of measurements on an individual patient basis. Follow-up echocardiograms may be of value to assess changes in symptom status.

## Echocardiography in clinical management of hypertension

### Stratification of risk in hypertension

The value of transthoracic echocardiography is recognized in the 2013 ESC/ESH guidelines,<sup>167</sup> where it is listed as a class II indication (level of evidence B) for cardiovascular risk assessment in asymptomatic adults with hypertension.<sup>177</sup> Transthoracic echocardiography received a high appropriate use criteria score of 8 (scale 1–9) for the initial evaluation of suspected hypertensive heart disease.<sup>178</sup> In this document, LV hypertrophy, LV diastolic dysfunction, and LA enlargement are described as specific signs of hypertensive heart disease. LV hypertrophy is recognized as evidence of target organ damage in hypertension by the Joint National Committee for the prevention, detection, and evaluation of high blood pressure (JNC 7) of the National High Blood Pressure Education Program (National Heart Lung and Blood Institute).<sup>179</sup>

In patients with hypertension, the type of LV remodelling (concentric remodelling, eccentric hypertrophy, and concentric hypertrophy) is predictive of the incidence of CV events. In particular,

the presence of LVH on echocardiography identifies hypertensive heart disease with a higher sensitivity and specificity compared with electrocardiography. Several population cohort studies have shown that LVH is predictive of cardiovascular and all-cause mortality, independent of blood pressure, and across all racial groups that have been studied. In the predominantly white population of the Framingham Study, for every 50 g/m<sup>2</sup> higher left ventricular mass index, there was a relative risk of death of 1.73 (95% CI 1.19–2.52), independent of blood pressure level.<sup>107</sup> In African-Americans enrolled in the ARIC study, LVH was associated with an increased risk of cardiovascular events (HR of 1.88 in men and 1.92 in women).<sup>180</sup> Similarly, for Native Americans enrolled in the Strong Heart Study, echocardiographic LVH also had additive discriminatory power over ECG LVH; the prevalence of LVH on echocardiography was 9.5% and was associated with a seven-fold increase in cardiovascular mortality and a four-fold increase in all-cause mortality.<sup>181</sup> Hispanic Americans showed a similar association of LVH and CVD mortality.<sup>182</sup> International studies have also confirmed a similar risk for CVD in hypertensive patients with LVH.<sup>183</sup> Concentric LVH on echocardiography identifies a high risk phenotype with abnormal flow-mediated dilation and decreased myocardial flow reserve.<sup>184</sup>

In symptomatic adults with hypertension, the echocardiogram provides additional assessments for systolic and diastolic dysfunction, as well as evaluation of wall motion abnormalities to detect underlying coronary artery disease. The use of echocardiography during treadmill or pharmacological testing is indicated in hypertensive patients with symptoms suggesting CHD and/or to estimate prognosis in patients with known concomitant coronary artery disease as well as those with known or suspected valvular heart disease. Patients with LVH, as well as related problems (abnormal resting ECG, left bundle-branch block, electronically paced rhythm, and digoxin therapy), also warrant pharmacological stress echocardiography.<sup>177</sup>

### Investigation of chest pain symptoms

Chest pain in patients with hypertension may signify concurrent coronary artery disease or may simply reflect subendocardial ischaemia due to LV hypertrophy and increased afterload. The diagnosis of coronary artery disease has particular challenges in this setting, because 'false-positive' results may occur when subendocardial ischaemia causes abnormal stress ECG or myocardial perfusion scan in the absence of flow-limiting epicardial coronary disease.<sup>185</sup> A normal stress electrocardiogram, performed to a high workload, has a high negative predictive value, but an abnormal or ambiguous test warrants further evaluation. There is some evidence in favour of preferential use of stress echocardiography for this purpose, because stress-induced wall motion abnormalities are highly specific for coronary artery disease, while perfusion defects in hypertensive patients may arise from abnormal myocardial flow reserve not due to epicardial coronary disease.<sup>186</sup> The lack of specificity of the coronary flow signal for epicardial coronary artery disease is also a problem when stress echocardiography is combined with the assessment of coronary flow reserve in hypertensive patients.<sup>187</sup> Finally, although hypertensive patients are at increased risk of coronary artery disease, screening for coronary disease is not recommended in asymptomatic patients because of the risk of false-positive results and uncertain management responses.

## Role in decision to initiate treatment

Effects of antihypertensive agents on LVM and other echocardiographic surrogate endpoints (e.g. LA size and diastolic function) have been extensively studied. Several large studies sponsored by the National Institutes of Health and the US Veterans Administration Cooperative Studies program have evaluated the effects of antihypertensive monotherapy. In general, it appears likely that there are differences between the efficacy of antihypertensive drugs and their effects on LVH. LVH regression does not adversely affect cardiac function and may be associated with improvements in diastolic function. However, although the finding of increased LVM on echocardiography could potentially guide selection of initial or intensity of therapy in hypertensive patients, JNC 7 recommendations do not risk stratify patients for treatment on the basis of target organ damage. Current guidelines recommend the use of combination treatment to get blood pressure to goal, thus blood pressure remains the primary target of therapy.

A part of the problem with getting a more central role for echocardiography to guide therapy is that despite the adverse prognosis associated with LVH in hypertension, there are inconsistent data from numerous studies that have evaluated the comparative efficacy of specific antihypertensive agents in LVH regression, as well as survival benefits associated with LVH regression. In a meta-analysis of 39 trials of antihypertensive therapy, angiotensin-converting enzyme inhibitors were the most effective agents, leading to a 13.3% reduction in LVM compared with 9.3% for calcium channel blockers, 6.8% for diuretics, and 5.5% for beta-blockers.<sup>188</sup> However, in a comparison of enalapril and long-acting nifedipine in patients with essential hypertension, the PRESERVE (Prospective Randomized Enalapril Study Evaluating Regression of Ventricular Enlargement) trial, systolic and diastolic pressures, as well as LV mass were reduced to a similar degree with both agents.<sup>189</sup> On the other hand, the LIFE (Losartan Intervention For Endpoint Reduction in Hypertension) trial echocardiographic sub-study demonstrated superior LVM reduction (21.7 g/m<sup>2</sup>) in patients treated with the angiotensin receptor blocker losartan compared with those treated with the beta-blocker atenolol (17.7 g/m<sup>2</sup>).<sup>190</sup> Finally, despite a 20% incidence of LVH regression with placebo, diuretic therapy with chlorthalidone and hydrochlorothiazide, respectively, demonstrated greater LVH regression over alternative agents in both the TOMHS (Treatment of Mild Hypertension Study) and Department of Veterans Affairs Cooperative Study Group on Antihypertensive Agents.<sup>191,192</sup> Similarly, left atrial size (itself a predictor of adverse outcomes<sup>31</sup>) was reduced with hydrochlorothiazide.<sup>193</sup>

In the recently defined category of pre-hypertension (systolic blood pressure 130–140 mmHg and/or diastolic blood pressure 80–90 mmHg), JNC 7 recommends intense lifestyle modification in such patients. Clinicians may obtain echocardiography to evaluate the presence of LV hypertrophy in such patients with pre-hypertension, particularly where there is a strong family history of hypertension and cardiovascular complications including stroke, heart failure, or dialysis. The community practice consensus is that the presence of LVH in such patients should lead to more aggressive approaches to lifestyle modification. There is increasing recognition that data on target organ involvement, including echocardiographic

LVH, may be important for young adults whose lifetime risk for hypertension is currently underestimated by most risk stratification models. However, no studies have examined whether a patient's knowledge of echocardiography demonstrating LVH will improve adherence to lifestyle modifications or pharmacological treatment of hypertension.

According to the National Health Service and National Institute for Health and Clinical Excellence (NICE) recent guideline update on the clinical management of primary hypertension in adults, there is uncertainty about how to assess the impact of blood pressure treatment in people aged <40 years with grade 1 hypertension and no overt target organ damage or CVD.<sup>194</sup> In particular, it is not known whether those with untreated hypertension are more likely to develop target organ damage and, if so, whether such damage is reversible. The writers of the NICE guideline further observe that target organ damage as surrogate or intermediate disease marker for CVD or hypertensive heart disease is the only indicator that is likely to be feasible in younger people because traditional clinical outcomes are unlikely to occur in sufficient numbers over the timeline of a typical clinical trial.

## Role in decisions to intensify treatment

The decision to intensify treatment of hypertension is currently guided by monitoring of clinic as well as home blood pressures. In patients who have hypertensive heart disease with LVH and normal systolic function, the value of periodic echocardiographic follow-up is not established; the Appropriate Use Task Force gave a score of 4 (may be appropriate) based on insufficient data for a stronger recommendation, regarding the re-evaluation of known hypertensive heart disease without a change in clinical status or cardiac examination.<sup>178</sup> However, echocardiography may be helpful in several scenarios. Patients with hypertensive heart disease who become symptomatic require follow-up echocardiography to evaluate systolic and diastolic function. Dissociation between blood pressure measurements and LV hypertrophy is an indication for further testing. The detection of high blood pressure without hypertrophy should lead to consideration of overestimation of the severity of hypertension, including ambulatory blood pressure monitoring or measurement of central aortic pressure.<sup>195</sup> When there is apparent LV hypertrophy in the setting of apparent blood pressure control, more detailed blood pressure evaluation (e.g. for masked hypertension) or identifying other causes of wall thickening such as infiltrative diseases should be considered.

## Use of echocardiography to monitor response to antihypertensive treatment

There is no current indication for the use of echocardiography to routinely monitor antihypertensive therapy, except as indicated and described in the section above for symptomatic patients or for patients with poor control of blood pressure. A recent intersocietal consensus document<sup>178</sup> on the appropriate use of echocardiography in clinical practice characterized its routine use for patients with hypertension without symptoms or signs of heart disease as 'rarely appropriate' with a value score of 3 out of 10.

## Relevance of hypertension to echocardiographic interpretation

Afterload is an important determinant of the assessment of cardiac function from ejection phase indices. Consequently, hypertension may have an important effect on the assessment of LV function in a variety of conditions. For example, an increment of blood pressure between visits may lead to an apparent deterioration of LV function when serial echocardiograms are being performed during chemotherapy or in the evaluation of valvular heart disease. In the assessment of aortic stenosis, arterial hypertension and the stenotic valve behave like serial resistors, and their combined impedance may explain symptom status.<sup>196</sup>

Likewise, in stress echocardiography, hypertension—especially a hypertensive response to stress—may provoke wall motion abnormalities or global LV dysfunction in the absence of coronary disease.<sup>197</sup> However, the impact of hypertensive LVH is probably less than in perfusion scintigraphy, where abnormal coronary flow reserve may produce false-positive perfusion abnormalities in the context of normal wall motion.<sup>198</sup>

### Recommendations

At present, decisions regarding the initiation, intensification, or monitoring of response to antihypertensive therapies are made based on clinical parameters.

Given the progressive nature of hypertensive cardiomyopathy, periodic evaluation of cardiac function and morphology by echocardiography may be warranted, especially if symptoms change.

## Recommendations for clinical laboratories

The value of echocardiography as a research tool in hypertension is uncontested. In a relatively short time, it has defined the cardiac structural and functional effects of hypertension, determined the prevalence of LVH and LV remodelling, determined the cardiac effects of antihypertensive therapy, and in epidemiological studies, provided fundamental insights into the relationships between blood pressure, genetic susceptibility, and LV mass. However, although it has been suggested that treatment choices in individual patients should be guided by echocardiographic findings, the value of echocardiography in the clinical management of hypertension is unproven.

The benefits of echocardiography will depend on its value in affecting treatment decisions, and in early identification and intervention in patients at risk who would not otherwise be treated. Moreover, demonstration of a value requires that the impact of echocardiography on clinical decisions is accompanied by improvement in patient outcome. Importantly, any consideration of the utility of echocardiography is contingent upon its reliability for the assessment of target measures such as LVM. However, little information is available on the impact of echocardiographic data on physician behaviour, or on patient outcomes in hypertension.

Previously, World Health Organization-International Society of Hypertension (WHO-ISH) suggested that drug treatment could be

withheld in hypertensive individuals with low cardiovascular risk based on non-echocardiographic criteria. However, echocardiographic findings in such individuals increases risk classification in 29% of such cases,<sup>199</sup> suggesting a role for echocardiography in risk profiling. However, recommendations for drug therapy at lower blood pressure levels may have made this application of echocardiography moot.

Another important limitation on the wider use of echocardiography is cost, both relative to benefit, and in competition for economic resources. In the USA alone, approximately 76.4 million adults have hypertension.<sup>200</sup> At even the arguably modest current Medicare/Medicaid reimbursement for echo of \$238, one echo per patient with hypertension would cost \$181.2 billion. Justification for this expenditure as an additional billable item would be difficult to provide. However, the development of hand-held ultrasound would allow suitably trained practitioners to obtain LV wall thickness and dimension information as part of the office visit. The effectiveness of this strategy remains unproven, especially in the light of training requirements, concern about interobserver variability, lack of standard quality assurance standards, and the increase in time for an office visit.

Given the above considerations, it has been recommended that echocardiography be reserved for those individuals with hypertension in whom hypertensive cardiac disease or cardiac disease in association with hypertension comorbidities is suspected. In such cases, a complete 2D and Doppler study should be performed, and the study not limited to evaluation of LVM/LVH. While calculation of LVM can readily be performed utilizing standard methods,<sup>46</sup> variability can be quite large, and current evidence does not support using LVM measurement to either initiate or modify hypertension treatment.

## Recommendations for research studies and clinical trials

Table 8 lists some potential areas where echocardiography (or other imaging) may help to guide management decisions in hypertension. The role of imaging in these settings is unproven and warrants further study.

Acquisition and interpretation of echocardiograms for research purposes in hypertension poses some special challenges. Even for clinically experienced sonographers, there is a significant learning curve present in recording technically adequate echocardiographic studies for the assessment of LVM, particularly in older subjects. In a Framingham analysis of M-mode echocardiograms performed in over 6000 subjects aged 17–90, the ability to record acceptable quality echocardiograms in subjects older than 60 years rose from a minimum of 28% during the first 5 months of the study to a maximum of 74–81% during studies 2 years later. Hence, echocardiography ‘drop-outs’ may not be randomly distributed, leading to the possibility of bias in data interpretation. Two-dimensional echocardiographic measurements were even more problematic than 2D-guided M-mode.

In previous large echocardiography trials, major differences in echo quality have existed between field centres. For example, in a 15 centre ventriculo-arterial trial of antihypertensive monotherapy,<sup>192</sup> the percent of readable echocardiograms for LVM varied

**Table 8** Potential sources of contribution of echocardiography on clinical management

Clinical subset	Echocardiographic target	Finding	Possible impact
Established hypertension	LVM or LVH	LVH	Selection of neurohormonal blockade (ACE inhibitors) or calcium blockers
Borderline hypertension 'White-coat' hypertension	LVM or LVH	Persistent LVH with therapy No LVH Unequivocal LVH	Question adequacy of BP control, check ambulatory BP, change drugs Follow closely Drug Rx
Haemodynamic profile	Cardiac output and total peripheral resistance	High output-low resistance High resistance-low output	Beta-blocker, diuretics, calcium blockers, ACE inhibitors, vasodilators
High risk for coronary artery disease	Regional wall motion Abnormality (RWMA)	RWMA present RWMA and ↓ LV function	Prior infarct-? Stress test Consider angiography; drug selection— 'anti-ischaemic' antihypertensive drugs
Hypertension in the elderly	Valvular disease, LV architecture	Aortic stenosis ↑ ↑ Relative wall thickness, small LV cavity	Caution with vasodilators, diuretics Avoid diuretics; avoid vasodilators

LV, left ventricular; LVH, left ventricular hypertrophy; Rx, therapy; ACE, angiotensin-converting enzyme inhibition.

from ~30 to 85%. This was not due to differences between centres in the proportion of easy or difficult patients. While the use of suboptimal equipment in some cases contributed to poor studies, the inter-centre differences were mostly because of variation in technical performance. Importantly, extensive previous clinical experience in echocardiography was no guarantee of high-quality echocardiograms for research purposes.

There is potential for differences in image acquisition styles that may exist between field centres in epidemiology studies, potential effects of instrumentation, continuing improvement in quality images obtained with newer generations of echo machines, and temporal intrareader drift in echo measurements and interpretations (e.g. LV walls may be read as thicker, or thinner at the beginning than the end of the clinical trial or observational study). All of these may produce not just large random variability in measurements and qualitative assessments, but substantial biases. For example, a temporal drift where readers might tend to read smaller wall thicknesses after months to years of experience with the study and patients receiving several treatments in the absence of a placebo control (common if not ubiquitous in clinical hypertension trials) may lead to the mistaken conclusion that both treatments are associated with decreased LVM and decreases in the proportion of individuals with LVH.

Several principles learned from clinical trials are applicable for echocardiography.<sup>201</sup> The acquisition of reproducible, correctly oriented images requires sonographer training. Monitoring of study quality is important. The inclusion of 'control' subjects is a protection against apparent changes due only to regression to the mean. The use of sample echocardiograms is a means of ensuring that all team members are applying the same methodology, and to prevent 'drift' over time.

## Recommendations for echocardiography in hypertension clinical trials

Given the large confidence intervals that may exist for measurement of LVM, it could be argued that treatment trials should recruit participants with markedly increased LVM. However, selection of

participants with values for LVM values substantially above (or below) the population mean can result in subsequent tests that reflect regression to the mean. Therefore, higher than 'true' values for LVM on an initial determination will tend to decrease on subsequent measurement. It is recommended that if possible, partition values for LVM not be used as requirements for entry into the study. If such values are used, then batch reading at completion of the study (with continuous monitoring of studies for acquisition quality) should be done. This may not be practical in long-term studies.

In creating categorical variables (e.g. LVH, LA enlargement, and abnormal annular tissue velocity), it is advisable when possible to use comparative control subjects from the same study to generate partition reference values. This is often possible in observational or epidemiologic studies, where participants without clinically prevalent disease (or better still—free of subclinical disease as well) can be utilized to derive partition values for continuous variables. Where those values are affected by age, body weight, height, gender, etc.—reference values can be derived from regression models used to derive a predicted value (with confidence limits) and express abnormality of a parameter by determining its ratio to this predicted value. However, this may not be possible in many clinical trials.

In large multicentre observational studies and clinical trials where all studies are read by a single core laboratory, the volume of studies can quickly become overwhelming. Special considerations exist re: management of workflow, but also vetting of site sonographers, participation in trial design, statistical power estimations, provision of ongoing quality assurance and improvement, data transmission to the statistical core, and issues regarding participant and investigator clinical alerts for abnormal findings. Specific considerations regarding core laboratory best practices have been described in a previous ASE EACVI expert consensus statement.<sup>202,203</sup>

**Conflict of interest:** This report is made available by EACVI and ASE as a courtesy reference source for members. This report contains recommendations only and should not be used as the sole basis to make medical practice decisions or for disciplinary action



against any employee. The statements and recommendations contained in this report are primarily based on the opinions of experts, rather than on scientifically verified data. EACVI and ASE make no express or implied warranties regarding the completeness or accuracy of the information in this report, including the warranty of merchantability or fitness for a particular purpose. In no event shall EACVI and ASE be liable to you, your patients, or any other third parties for any decision made or action taken by you or such other parties in reliance on this information. Nor does your use of this information constitute the offering of medical advice by EACVI and ASE or create any physician–patient relationship between EACVI/ASE and your patients or anyone else.

## References

- Jennings G. Obesity and left ventricular hypertrophy: does my heart look big on this? *J Hypertens* 2010;**28**:2190–3.
- Brumback LC, Kronmal R, Heckbert SR, Ni H, Hundley WG, Lima JA *et al*. Body size adjustments for left ventricular mass by cardiovascular magnetic resonance and their impact on left ventricular hypertrophy classification. *Int J Cardiovasc Imaging* 2010;**26**:459–68.
- Chirinos JA, Segers P, De Buyzere ML, Kronmal RA, Raja MW, De Bacquer D *et al*. Left ventricular mass: allometric scaling, normative values, effect of obesity, and prognostic performance. *Hypertension* 2010;**56**:91–8.
- Lauer MS, Anderson KM, Larson MG, Levy D. A new method for indexing left ventricular mass for differences in body size. *Am J Cardiol* 1994;**74**:487–91.
- Gaasch WH, Zile MR. Left ventricular structural remodeling in health and disease: with special emphasis on volume, mass, and geometry. *J Am Coll Cardiol* 2011;**58**:1733–40.
- Gjesdal O, Bluemke DA, Lima JA. Cardiac remodeling at the population level—risk factors, screening, and outcomes. *Nat Rev Cardiol* 2011;**8**:673–85.
- Natori S, Lai S, Finn JP, Gomes AS, Hundley WG, Jerosch-Herold M *et al*. Cardiovascular function in multi-ethnic study of atherosclerosis: normal values by age, sex, and ethnicity. *AJR Am J Roentgenol* 2006;**186**:S357–65.
- Salton CJ, Chuang ML, O'Donnell CJ, Kupka MJ, Larson MG, Kissinger KV *et al*. Gender differences and normal left ventricular anatomy in an adult population free of hypertension. A cardiovascular magnetic resonance study of the Framingham Heart Study offspring cohort. *J Am Coll Cardiol* 2002;**39**:1055–60.
- Bella JN, Devereux RB, Roman MJ, O'Grady MJ, Welty TK, Lee ET *et al*. Relations of left ventricular mass to fat-free and adipose body mass: the strong heart study. The Strong Heart Study Investigators. *Circulation* 1998;**98**:2538–44.
- Mohammed SF, Borlaug BA, Roger VL, Mirzoyev SA, Rodeheffer RJ, Chirinos JA *et al*. Comorbidity and ventricular and vascular structure and function in heart failure with preserved ejection fraction: a community-based study. *Circ Heart Fail* 2012;**5**:710–9.
- de Simone G, Devereux RB. Method errors or unexplained biological information? *Hypertension* 2010;**56**:e177–8.
- Cheng S, Fernandes VR, Bluemke DA, McClelland RL, Kronmal RA, Lima JA. Age-related left ventricular remodeling and associated risk for cardiovascular outcomes: the multi-ethnic study of atherosclerosis. *Circ Cardiovasc Imaging* 2009;**2**:191–8.
- McMullen JR, Jennings GL. Differences between pathological and physiological cardiac hypertrophy: novel therapeutic strategies to treat heart failure. *Clin Exp Pharmacol Physiol* 2007;**34**:255–62.
- Turkbey EB, McClelland RL, Kronmal RA, Burke GL, Bild DE, Tracy RP *et al*. The impact of obesity on the left ventricle: the multi-ethnic study of atherosclerosis (MESA). *JACC Cardiovasc Imaging* 2010;**3**:266–74.
- Lauer MS, Anderson KM, Kannel WB, Levy D. The impact of obesity on left ventricular mass and geometry. The Framingham Heart Study. *JAMA* 1991;**266**:231–6.
- Cheng S, Xanthakis V, Sullivan LM, Lieb W, Massaro J, Aragam J *et al*. Correlates of echocardiographic indices of cardiac remodeling over the adult life course: longitudinal observations from the Framingham Heart Study. *Circulation* 2010;**122**:570–8.
- Bella JN, Devereux RB, Roman MJ, Palmieri V, Liu JE, Paranicas M *et al*. Separate and joint effects of systemic hypertension and diabetes mellitus on left ventricular structure and function in American Indians (the Strong Heart Study). *Am J Cardiol* 2001;**87**:1260–5.
- Palmieri V, Bella JN, Arnett DK, Liu JE, Oberman A, Schuck MY *et al*. Effect of type 2 diabetes mellitus on left ventricular geometry and systolic function in hypertensive subjects: Hypertension Genetic Epidemiology Network (HyperGEN) study. *Circulation* 2001;**103**:102–7.
- Ermade L, Bergerot C, Rietzschel ER, De Buyzere ML, Thibault H, Pignonblanc PG *et al*. Diastolic dysfunction in patients with type 2 diabetes mellitus: is it really the first marker of diabetic cardiomyopathy? *J Am Soc Echocardiogr* 2011;**24**:1268–75, e1261.
- Bella JN, MacCluer JW, Roman MJ, Almay L, North KE, Best LG *et al*. Heritability of left ventricular dimensions and mass in American Indians: the Strong Heart Study. *J Hypertens* 2004;**22**:281–6.
- Lam CS, Liu X, Yang Q, Larson MG, Pencina MJ, Aragam J *et al*. Familial aggregation of left ventricular geometry and association with parental heart failure: the Framingham Heart Study. *Circ Cardiovasc Genet* 2010;**3**:492–8.
- Poppe KK, Bachmann ME, Triggs CM, Doughty RN, Whalley GA. Geographic variation in left ventricular mass and mass index: a systematic review. *J Hum Hypertens* 2012;**26**:420–9.
- Bonow RO, Mann DL, Zipes DP, Libby P. *Braunwald's Heart Disease: A Textbook of Cardiovascular Medicine, 2-Volume Set*. Boston: Elsevier Health Sciences; 2011.
- Leite-Moreira AF. Current perspectives in diastolic dysfunction and diastolic heart failure. *Heart* 2006;**92**:712–8.
- Meerson FZ. Compensatory hyperfunction of the heart and cardiac insufficiency. *Circ Res* 1962;**10**:250–8.
- Gillebert TC, Lew WY. Influence of systolic pressure profile on rate of left ventricular pressure fall. *Am J Physiol* 1991;**261**:H805–13.
- Chirinos JA, Segers P, Rietzschel ER, De Buyzere ML, Raja MW, Claessens T *et al*. Early and late systolic wall stress differentially relate to myocardial contraction and relaxation in middle-aged adults: the Asklepios study. *Hypertension* 2013;**61**:296–303.
- Kobayashi S, Yano M, Kohno M, Obayashi M, Hisamatsu Y, Ryoke T *et al*. Influence of aortic impedance on the development of pressure-overload left ventricular hypertrophy in rats. *Circulation* 1996;**94**:3362–8.
- Lang RM, Badano L, Afalalo J, Chamber Quantification Writing Group, American Society of Echocardiography's Guidelines, Standards Committee, European Association of Echocardiography. Recommendations for cardiac chamber quantification by echocardiography: an update from the American Society of Echocardiography and the European Association of Cardiovascular Imaging. *J Am Soc Echocardiogr* 2015;**28**:1–39.
- Tsang TS, Abhayaratna WVP, Barnes ME, Miyasaka Y, Gersh BJ, Bailey KR *et al*. Prediction of cardiovascular outcomes with left atrial size: is volume superior to area or diameter? *J Am Coll Cardiol* 2006;**47**:1018–23.
- Benjamin EJ, D'Agostino RB, Belanger AJ, Wolf PA, Levy D. Left atrial size and the risk of stroke and death: the Framingham Heart study. *Circulation* 1995;**92**:835–41.
- Cuspidi C, Meani S, Fusi V, Valerio C, Catini E, Sala C *et al*. Prevalence and correlates of left atrial enlargement in essential hypertension: role of ventricular geometry and the metabolic syndrome: the evaluation of target organ damage in hypertension study. *J Hypertens* 2005;**23**:875–82.
- Rackley CE, Dodge HT, Coble YD Jr, Hay RE. A method for determining left ventricular mass in man. *Circulation* 1964;**29**:666–71.
- Deague JA, Wilson CM, Grigg LE, Harrap SB. Discrepancies between echocardiographic measurements of left ventricular mass in a healthy adult population. *Clin Sci (Lond)* 1999;**97**:377–83.
- Devereux RB, Reichek N. Echocardiographic determination of left ventricular mass in man. Anatomic validation of the method. *Circulation* 1977;**55**:613–8.
- Reichek N, Helak J, Plappert T, Sutton MS, Weber KT. Anatomic validation of left ventricular mass estimates from clinical two-dimensional echocardiography: initial results. *Circulation* 1983;**67**:348–52.
- Henry WL, Gardin JM, Ware JH. Echocardiographic measurements in normal subjects from infancy to old age. *Circulation* 1980;**62**:1054–61.
- Devereux RB, Lutas EM, Casale PN, Kligfield P, Eisenberg RR, Hammond IW *et al*. Standardization of m-mode echocardiographic left ventricular anatomic measurements. *J Am Coll Cardiol* 1984;**4**:1222–30.
- Hammond IW, Devereux RB, Alderman MH, Lutas EM, Spitzer MC, Crowley JS *et al*. The prevalence and correlates of echocardiographic left ventricular hypertrophy among employed patients with uncomplicated hypertension. *J Am Coll Cardiol* 1986;**7**:639–50.
- Byrd BF III, Wahr D, Wang YS, Bouchard A, Schiller NB. Left ventricular mass and volume/mass ratio determined by two-dimensional echocardiography in normal adults. *J Am Coll Cardiol* 1985;**6**:1021–5.
- Levy D, Savage DD, Garrison RJ, Anderson KM, Kannel WB, Castelli WP. Echocardiographic criteria for left ventricular hypertrophy: the Framingham Heart study. *Am J Cardiol* 1987;**59**:956–60.
- Koren MJ, Devereux RB, Casale PN, Savage DD, Laragh JH. Relation of left ventricular mass and geometry to morbidity and mortality in uncomplicated essential hypertension. *Ann Intern Med* 1991;**114**:345–52.
- de Simone G, Daniels SR, Devereux RB, Meyer RA, Roman MJ, de Divitiis O *et al*. Left ventricular mass and body size in normotensive children and adults: assessment of allometric relations and impact of overweight. *J Am Coll Cardiol* 1992;**20**:1251–60.

44. Kuch B, Hense HW, Gneiting B, Doring A, Muscholl M, Brockel U et al. Body composition and prevalence of left ventricular hypertrophy. *Circulation* 2000;**102**: 405–10.
45. De Ridder S, Suttrop MJ, Ernst SM, Six JA, Mannaerts HF, Kamp O et al. Percutaneous transcatheter closure of atrial septal defects: initial single-centre experience and follow-up results. Initial experience with three-dimensional echocardiography. *Acta Cardiol* 2005;**60**:171–8.
46. Lang RM, Bierig M, Devereux RB, Flachskampf FA, Foster E, Pellikka PA et al. Recommendations for chamber quantification. *Eur J Echocardiogr* 2006;**7**:79–108.
47. Helak JW, Reichek N. Quantitation of human left ventricular mass and volume by two-dimensional echocardiography: in vitro anatomic validation. *Circulation* 1981;**63**:1398–407.
48. Fukuda S, Watanabe H, Daimon M, Abe Y, Hirashiki A, Hirata K et al. Normal values of real-time 3-dimensional echocardiographic parameters in a healthy Japanese population: the JAMP-3D study. *Circ J* 2012;**76**:1177–81.
49. Muraru D, Badano LP, Peluso D, Dal Bianco L, Casablanca S, Kocabay G et al. Comprehensive analysis of left ventricular geometry and function by three-dimensional echocardiography in healthy adults. *J Am Soc Echocardiogr* 2013;**26**:618–28.
50. Jenkins C, Bricknell K, Hanekom L, Marwick TH. Reproducibility and accuracy of echocardiographic measurements of left ventricular parameters using real-time three-dimensional echocardiography. *J Am Coll Cardiol* 2004;**44**:878–86.
51. Takeuchi M, Nishikage T, Mor-Avi V, Sugeng L, Weinert L, Nakai H et al. Measurement of left ventricular mass by real-time three-dimensional echocardiography: validation against magnetic resonance and comparison with two-dimensional and M-mode measurements. *J Am Soc Echocardiogr* 2008;**21**:1001–5.
52. van den Bosch AE, Robbers-Visser D, Krenning BJ, McGhie JS, Helbing WA, Meijboom FJ et al. Comparison of real-time three-dimensional echocardiography to magnetic resonance imaging for assessment of left ventricular mass. *Am J Cardiol* 2006;**97**:113–7.
53. Shimada YJ, Shiota T. Meta-analysis of accuracy of left ventricular mass measurement by three-dimensional echocardiography. *Am J Cardiol* 2012;**110**:445–52.
54. Krishnamoorthy A, Brown T, Ayers CR, Gupta S, Rame JE, Patel PC et al. Progression from normal to reduced left ventricular ejection fraction in patients with concentric left ventricular hypertrophy after long-term follow-up. *Am J Cardiol* 2011;**108**:997–1001.
55. Masiha S, Sundstrom J, Lind L. Left ventricular geometric patterns and adaptations to hemodynamics are similar in elderly men and women. *BMC Cardiovasc Disord* 2011;**11**:25.
56. Tsioufis C, Taxiarchou E, Syrseloudis D, Chatzis D, Tsiachris D, Chatzistamatiou E et al. Left ventricular mass but not geometry determines left atrial size in the early stages of hypertension. *J Hum Hypertens* 2009;**23**:674–9.
57. Mizuguchi Y, Oishi Y, Miyoshi H, Iuchi A, Nagase N, Oki T. Concentric left ventricular hypertrophy brings deterioration of systolic longitudinal, circumferential, and radial myocardial deformation in hypertensive patients with preserved left ventricular pump function. *J Cardiol* 2010;**55**:23–33.
58. Masugata H, Senda S, Inukai M, Muraō K, Hosomi N, Iwado Y et al. Differences in left ventricular diastolic dysfunction between eccentric and concentric left ventricular hypertrophy in hypertensive patients with preserved systolic function. *J Int Med Res* 2011;**39**:772–9.
59. Mannaerts HF, van der Heide JA, Kamp O, Stoel MG, Twisk J, Visser CA. Early identification of left ventricular remodelling after myocardial infarction, assessed by transthoracic 3D echocardiography. *Eur Heart J* 2004;**25**:680–7.
60. Cameli M, Lisi M, Righini FM, Massoni A, Mondillo S. Left ventricular remodeling and torsion dynamics in hypertensive patients. *Int J Cardiovasc Imaging* 2013;**29**:79–86.
61. Khouri MG, Peshock RM, Ayers CR, de Lemos JA, Drazner MH. A 4-tiered classification of left ventricular hypertrophy based on left ventricular geometry: the Dallas Heart Study. *Circ Cardiovasc Imaging* 2010;**3**:164–71.
62. Dianzumba SB, DiPette D, Joyner CR, Townsend R, Weber E, Mauro K et al. Left ventricular function in mild hypertension after adrenergic blockade. *Hypertension* 1988;**11**:198–102.
63. Diez J. Towards a new paradigm about hypertensive heart disease. *Med Clin North Am* 2009;**93**:637–45.
64. Weber KT, Brilla CG. Pathological hypertrophy and cardiac interstitium. Fibrosis and renin-angiotensin-aldosterone system. *Circulation* 1991;**83**:1849–65.
65. Diez J, Gonzalez A, Lopez B, Querejeta R. Mechanisms of disease: pathologic structural remodeling is more than adaptive hypertrophy in hypertensive heart disease. *Nat Clin Pract Cardiovasc Med* 2005;**2**:209–16.
66. Kalam K, Otahal P, Marwick TH. Prognostic implications of global LV dysfunction: a systematic review and meta-analysis of global longitudinal strain and ejection fraction. *Heart* 2014;**100**:1673–80.
67. Weidemann F, Niemann M, Ertl G, Stork S. The different faces of echocardiographic left ventricular hypertrophy: clues to the etiology. *J Am Soc Echocardiogr* 2010;**23**: 793–801.
68. Di Bello V, Pedrinelli R, Talini E, Giorgi D, Bertini A, Dell’Omo G et al. Ultrasonic myocardial tissue characterization: a methodological review. *Ital Heart J* 2001;**2**: 333–43.
69. Lythall DA, Bishop J, Greenbaum RA, Ilsley CJ, Mitchell AG, Gibson DG et al. Relationship between myocardial collagen and echo amplitude in non-fibrotic hearts. *Eur Heart J* 1993;**14**:344–50.
70. Mizuno R, Fujimoto S, Saito Y, Nakamura S. Non-invasive quantitation of myocardial fibrosis using combined tissue harmonic imaging and integrated backscatter analysis in dilated cardiomyopathy. *Cardiology* 2007;**108**:11–7.
71. Di Bello V, Pedrinelli R, Bianchi M, Giorgi D, Bertini A, Valenti G et al. Ultrasonic myocardial texture in hypertensive mild-to-moderate left ventricular hypertrophy: a videodensitometric study. *Am J Hypertens* 1998;**11**:155–64.
72. Kim RJ, Wu E, Rafael A, Chen EL, Parker MA, Simonetti O et al. The use of contrast-enhanced magnetic resonance imaging to identify reversible myocardial dysfunction. *N Engl J Med* 2000;**343**:1445–53.
73. Rudolph A, Abdel-Aty H, Bohl S, Boye P, Zagrosek A, Dietz R et al. Noninvasive detection of fibrosis applying contrast-enhanced cardiac magnetic resonance in different forms of left ventricular hypertrophy relation to remodeling. *J Am Coll Cardiol* 2009;**53**:284–91.
74. Moreo A, Ambrosio G, De Chiara B, Pu M, Tran T, Mauri F et al. Influence of myocardial fibrosis on left ventricular diastolic function: noninvasive assessment by cardiac magnetic resonance and echo. *Circ Cardiovasc Imaging* 2009;**2**:437–43.
75. Iles L, Pfluger H, Phrommintikul A, Cherayath J, Aksit P, Gupta SN et al. Evaluation of diffuse myocardial fibrosis in heart failure with cardiac magnetic resonance contrast-enhanced T1 mapping. *J Am Coll Cardiol* 2008;**52**:1574–80.
76. van den Borne SW, Isobe S, Verjans JW, Petrov A, Lovhaug D, Li P et al. Molecular imaging of interstitial alterations in remodeling myocardium after myocardial infarction. *J Am Coll Cardiol* 2008;**52**:2017–28.
77. Gonzalez A, Fortunato MA, Querejeta R, Ravassa S, Lopez B, Lopez N et al. Cardiomyocyte apoptosis in hypertensive cardiomyopathy. *Cardiovasc Res* 2003;**59**: 549–62.
78. Janardhanan R, Desai AS, Solomon SD. Therapeutic approaches to diastolic dysfunction. *Curr Hypertens Rep* 2009;**11**:283–91.
79. Marchais SJ, Guerin AP, Pannier B, Delavaud G, London GM. Arterial compliance and blood pressure. *Drugs* 1993;**46**(Suppl 2):82–7.
80. Chirinos JA, Segers P, Gillebert TC, Gupta AK, De Buyzere ML, De Bacquer D et al. Arterial properties as determinants of time-varying myocardial stress in humans. *Hypertension* 2012;**60**:64–70.
81. Mitchell GF, Guo CY, Benjamin EJ, Larson MG, Keyes MJ, Vita JA et al. Cross-sectional correlates of increased aortic stiffness in the community: the Framingham Heart study. *Circulation* 2007;**115**:2628–36.
82. Weber T. Wave reflection in acute ischemic stroke. *Am J Hypertens* 2010;**23**:704.
83. Chirinos JA, Kips JG, Jacobs DR Jr, Brumback L, Duprez DA, Kronmal R et al. Arterial wave reflections and incident cardiovascular events and heart failure: MESA (multiethnic study of atherosclerosis). *J Am Coll Cardiol* 2012;**60**:2170–7.
84. De Tombe PP, Jones S, Burkhoff D, Hunter WC, Kass DA. Ventricular stroke work and efficiency both remain nearly optimal despite altered vascular loading. *Am J Physiol* 1993;**264**:H1817–24.
85. Claessens TE, Rietzschel ER, De Buyzere ML, De Bacquer D, De Backer G, Gillebert TC et al. Noninvasive assessment of left ventricular and myocardial contractility in middle-aged men and women: disparate evolution above the age of 50? *Am J Physiol Heart Circ Physiol* 2007;**292**:H856–65.
86. Redfield MM, Jacobsen SJ, Borlaug BA, Rodeheffer RJ, Kass DA. Age- and gender-related ventricular-vascular stiffening: a community-based study. *Circulation* 2005;**112**:2254–62.
87. Chen CH, Fetis B, Nevo E, Rochitte CE, Chiou KR, Ding PA et al. Noninvasive single-beat determination of left ventricular end-systolic elastance in humans. *J Am Coll Cardiol* 2001;**38**:2028–34.
88. Senzaki H, Chen CH, Kass DA. Single-beat estimation of end-systolic pressure-volume relation in humans. A new method with the potential for noninvasive application. *Circulation* 1996;**94**:2497–506.
89. Chirinos JA, Segers P. Noninvasive evaluation of left ventricular afterload: part 1: pressure and flow measurements and basic principles of wave conduction and reflection. *Hypertension* 2010;**56**:555–62.
90. Evangelista A, Flachskampf FA, Erbel R, Antonini-Canterin F, Vlachopoulos C, Rocchi G et al. Echocardiography in aortic diseases: EAE recommendations for clinical practice. *Eur J Echocardiogr* 2010;**11**:645–58.
91. Schiller NB, Shah PM, Crawford M, DeMaria A, Devereux R, Feigenbaum H et al. Recommendations for quantitation of the left ventricle by two-dimensional echocardiography. American Society of Echocardiography Committee on standards, subcommittee on quantitation of two-dimensional echocardiograms. *J Am Soc Echocardiogr* 1989;**2**:358–67.
92. Otterstad JE, Froeland G, St John Sutton M, Holme I. Accuracy and reproducibility of biplane two-dimensional echocardiographic measurements of left ventricular dimensions and function. *Eur Heart J* 1997;**18**:507–13.

93. Lafitte S, Lasserre R, Couffignal T, Dos Santos P, Coste P, Roudaut R. [Superiority of second harmonic imaging for echocardiographic measurement of LEF ventricular volumes. Comparison with angiocardiology]. *Arch Mal Coeur Vaiss* 1999;**92**: 867–74.
94. Grothues F, Smith GC, Moon JC, Bellenger NG, Collins P, Klein HU *et al*. Comparison of interstudy reproducibility of cardiovascular magnetic resonance with two-dimensional echocardiography in normal subjects and in patients with heart failure or left ventricular hypertrophy. *Am J Cardiol* 2002;**90**:29–34.
95. Quinones MA, Gaasch WH, Cole JS, Alexander JK. Echocardiographic determination of left ventricular stress-velocity relations. *Circulation* 1975;**51**:689–700.
96. Jenkins C, Moir S, Chan J, Rakhit D, Haluska B, Marwick TH. Left ventricular volume measurement with echocardiography: a comparison of left ventricular opacification, three-dimensional echocardiography, or both with magnetic resonance imaging. *Eur Heart J* 2009;**30**:98–106.
97. Dorosz JL, Lezotte DC, Weitzenkamp DA, Allen LA, Salcedo EE. Performance of 3-dimensional echocardiography in measuring left ventricular volumes and ejection fraction: a systematic review and meta-analysis. *J Am Coll Cardiol* 2012;**59**: 1799–808.
98. Hung J, Lang R, Flachskampf F, Sherman SK, McCulloch ML, Adams DB *et al*. 3D echocardiography: a review of the current status and future directions. *J Am Soc Echocardiogr* 2007;**20**:213–33.
99. Monaghan MJ. Role of real time 3D echocardiography in evaluating the left ventricle. *Heart* 2006;**92**:131–6.
100. Lang RM, Badano LP, Tsang W, Adams DH, Agricola E, Buck T *et al*. EAE/ASE recommendations for image acquisition and display using three-dimensional echocardiography. *J Am Soc Echocardiogr* 2012;**25**:3–46.
101. Chahal NS, Lim TK, Jain P, Chambers JC, Kooner JS, Senior R. Population-based reference values for 3D echocardiographic LV volumes and ejection fraction. *JACC Cardiovasc Imaging* 2012;**5**:1191–7.
102. Chukwu EO, Barasch E, Mihalatos DG, Katz A, Lachmann J, Han J *et al*. Relative importance of errors in left ventricular quantitation by two-dimensional echocardiography: insights from three-dimensional echocardiography and cardiac magnetic resonance imaging. *J Am Soc Echocardiogr* 2008;**21**:990–7.
103. Thavendiranathan P, Liu S, Verhaert D, Calleja A, Nitinunu A, Van Houten T *et al*. Feasibility, accuracy, and reproducibility of real-time full-volume 3D transthoracic echocardiography to measure lv volumes and systolic function: a fully automated endocardial contouring algorithm in sinus rhythm and atrial fibrillation. *JACC Cardiovasc Imaging* 2012;**5**:239–51.
104. Shimizu G, Hirota Y, Kita Y, Kawamura K, Saito T, Gaasch WH. Left ventricular midwall mechanics in systemic arterial hypertension. Myocardial function is depressed in pressure-overload hypertrophy. *Circulation* 1991;**83**:1676–84.
105. Palmom LC, Reichek N, Yeon SB, Clark NR, Brownson D, Hoffman E *et al*. Intramural myocardial shortening in hypertensive left ventricular hypertrophy with normal pump function. *Circulation* 1994;**89**:122–31.
106. Rademakers FE, Rogers WJ, Guier WH, Hutchins GM, Siu CO, Weisfeldt ML *et al*. Relation of regional cross-fiber shortening to wall thickening in the intact heart. Three-dimensional strain analysis by NMR tagging. *Circulation* 1994;**89**:1174–82.
107. Levy D, Garrison RJ, Savage DD, Kannel WB, Castelli WP. Prognostic implications of echocardiographically determined left ventricular mass in the Framingham Heart study. *N Engl J Med* 1990;**322**:1561–6.
108. de Simone G, Devereux RB, Koren MJ, Mensah GA, Casale PN, Laragh JH. Midwall left ventricular mechanics. An independent predictor of cardiovascular risk in arterial hypertension. *Circulation* 1996;**93**:259–65.
109. de Simone G, Devereux RB, Roman MJ, Ganau A, Saba PS, Alderman MH *et al*. Assessment of left ventricular function by the midwall fractional shortening/end-systolic stress relation in human hypertension. *J Am Coll Cardiol* 1994;**23**:1444–51.
110. Greenbaum RA, Ho SY, Gibson DG, Becker AE, Anderson RH. Left ventricular fibre architecture in man. *Br Heart J* 1981;**45**:248–63.
111. Pearlman ES, Weber KT, Janicki JS, Pietra GG, Fishman AP. Muscle fiber orientation and connective tissue content in the hypertrophied human heart. *Lab Invest* 1982;**46**:158–64.
112. Freeman GL, LeWinter MM, Engler RL, Covell JW. Relationship between myocardial fiber direction and segment shortening in the midwall of the canine left ventricle. *Circ Res* 1985;**56**:31–9.
113. Aurigemma GP, Gaasch WH, McLaughlin M, McGinn R, Sweeney A, Meyer TE. Reduced left ventricular systolic pump performance and depressed myocardial contractile function in patients >65 years of age with normal ejection fraction and a high relative wall thickness. *Am J Cardiol* 1995;**76**:702–5.
114. de Simone G, Devereux RB. Rationale of echocardiographic assessment of left ventricular wall stress and midwall mechanics in hypertensive heart disease. *Eur J Echocardiogr* 2002;**3**:192–8.
115. Shimizu G, Conrad CH, Gaasch WH. Phase-plane analysis of left ventricular chamber filling and midwall fiber lengthening in patients with left ventricular hypertrophy. *Circulation* 1987;**75**:134–9.
116. Ballo P, Mondillo S, Guerrini F, Barbati R, Picchi A, Focardi M. Midwall mechanics in physiologic and hypertensive concentric hypertrophy. *J Am Soc Echocardiogr* 2004;**17**:418–27.
117. Calabro R, Pisacane C, Pacileo G, Russo MG. Left ventricular midwall mechanics in healthy children and adolescents. *J Am Soc Echocardiogr* 1999;**12**:932–40.
118. Slotwiner DJ, Devereux RB, Schwartz JE, Pickering TG, de Simone G, Ganau A *et al*. Relation of age to left ventricular function in clinically normal adults. *Am J Cardiol* 1998;**82**:621–6.
119. Park K, Chang SA, Kim HK, Park HE, Na SH, Kim YJ *et al*. Normal ranges and physiological changes of midwall fractional shortening in healthy Korean population. *Korean Circ J* 2010;**40**:587–92.
120. Crepez R, Cemin R, Pedron C, Gentili L, Trevisan D, Pitscheider W. Age-related variations of left ventricular endocardial and midwall function in healthy infants, children, and adolescents. *Ital Heart J* 2005;**6**:634–9.
121. Zabalgaitia M, Rahman SN, Haley WE, Yarows S, Krause L, Anderson LC *et al*. Effect of regression of left ventricular hypertrophy from systemic hypertension on systolic function assessed by midwall shortening (hot echocardiographic study). *Am J Cardiol* 2001;**88**:521–5.
122. Wachtell K, Gerds E, Palmieri V, Olsen MH, Nieminen MS, Papademetriou V *et al*. In-treatment midwall and endocardial fractional shortening predict cardiovascular outcome in hypertensive patients with preserved baseline systolic ventricular function: the losartan intervention for endpoint reduction study. *J Hypertens* 2010;**28**: 1541–6.
123. Novelli GP, Vasapollo B, Gagliardi G, Tiralongo GM, Pisani I, Manfellotto D *et al*. Left ventricular midwall mechanics at 24 weeks' gestation in high-risk normotensive pregnant women: relationship to placenta-related complications of pregnancy. *Ultrasound Obstet Gynecol* 2012;**39**:430–7.
124. Jacobs LD, Salgo IS, Goonewardena S, Weinert L, Coon P, Bardo D *et al*. Rapid online quantification of left ventricular volume from real-time three-dimensional echocardiographic data. *Eur Heart J* 2006;**27**:460–8.
125. Jung HO, Sheehan FH, Bolson EL, Waiss MP, Otto CM. Evaluation of midwall systolic function in left ventricular hypertrophy: a comparison of 3-dimensional versus 2-dimensional echocardiographic indices. *J Am Soc Echocardiogr* 2006;**19**:802–10.
126. Yoshikawa H, Suzuki M, Hashimoto G, Kusunose Y, Otsuka T, Nakamura M *et al*. Midwall ejection fraction for assessing systolic performance of the hypertrophic left ventricle. *Cardiovasc Ultrasound* 2012;**10**:45.
127. Galderisi M, Lomoriello VS, Santoro A, Esposito R, Olibet M, Raia R *et al*. Differences of myocardial systolic deformation and correlates of diastolic function in competitive rowers and young hypertensives: a speckle-tracking echocardiography study. *J Am Soc Echocardiogr* 2010;**23**:1190–8.
128. Gulati VK, Katz WE, Follansbee V, Gorcsan J III. Mitral annular descent velocity by tissue Doppler echocardiography as an index of global left ventricular function. *Am J Cardiol* 1996;**77**:979–84.
129. Shan K, Bick RJ, Poindexter BJ, Shimoni S, Letsou GV, Reardon MJ *et al*. Relation of tissue Doppler derived myocardial velocities to myocardial structure and beta-adrenergic receptor density in humans. *J Am Coll Cardiol* 2000;**36**:891–6.
130. Ruan Q, Nagueh SF. Usefulness of isovolumic and systolic ejection signals by tissue Doppler for the assessment of left ventricular systolic function in ischemic or idiopathic dilated cardiomyopathy. *Am J Cardiol* 2006;**97**:872–5.
131. Derumeaux G, Ovize M, Loufoua J, Andre-Fouet X, Minaire Y, Cribier A *et al*. Doppler tissue imaging quantitates regional wall motion during myocardial ischemia and reperfusion. *Circulation* 1998;**97**:1970–7.
132. Shimizu Y, Uematsu M, Shimizu H, Nakamura K, Yamagishi M, Miyatake K. Peak negative myocardial velocity gradient in early diastole as a noninvasive indicator of left ventricular diastolic function: comparison with transmitral flow velocity indices. *J Am Coll Cardiol* 1998;**32**:1418–25.
133. Hu K, Liu D, Niemann M, Herrmann S, Gaudron PD, Ertl G *et al*. Methods for assessment of left ventricular systolic function in technically difficult patients with poor imaging quality. *J Am Soc Echocardiogr* 2013;**26**:105–13.
134. Mor-Avi V, Lang RM, Badano LP, Belohlavek M, Cardim NM, Derumeaux G *et al*. Current and evolving echocardiographic techniques for the quantitative evaluation of cardiac mechanics: ASE/EAE consensus statement on methodology and indications endorsed by the Japanese Society of Echocardiography. *Eur J Echocardiogr* 2011;**12**:167–205.
135. Nikitin NP, Loh PH, Silva R, Ghosh J, Khaleva OY, Goode K *et al*. Prognostic value of systolic mitral annular velocity measured with Doppler tissue imaging in patients with chronic heart failure caused by left ventricular systolic dysfunction. *Heart* 2006;**92**:775–9.
136. Vinereanu D, Florescu N, Sculthorpe N, Tweddell AC, Stephens MR, Fraser AG. Differentiation between pathologic and physiologic left ventricular hypertrophy by tissue Doppler assessment of long-axis function in patients with hypertrophic cardiomyopathy or systemic hypertension and in athletes. *Am J Cardiol* 2001;**88**: 53–8.
137. Cardim N, Longo S, Ferreira T, Pereira A, Gouveia A, Reis RP *et al*. Tissue Doppler imaging assessment of long axis left ventricular function in hypertensive patients

- with concentric left ventricular hypertrophy: differential diagnosis with hypertrophic cardiomyopathy. *Rev Port Cardiol* 2002;**21**:709–40.
138. De Sutter J, De Backer J, Van de Veire N, Velghe A, De Buyzere M, Gillebert TC. Effects of age, gender, and left ventricular mass on septal mitral annulus velocity ( $e'$ ) and the ratio of transmitral early peak velocity to  $e'$  ( $e'/e'$ ). *Am J Cardiol* 2005;**95**:1020–3.
  139. Abraham TP, Dimaano VL, Liang HY. Role of tissue Doppler and strain echocardiography in current clinical practice. *Circulation* 2007;**116**:2597–609.
  140. Geyer H, Caracciolo G, Abe H, Wilansky S, Carerj S, Gentile F et al. Assessment of myocardial mechanics using speckle tracking echocardiography: fundamentals and clinical applications. *J Am Soc Echocardiogr* 2010;**23**:351–69 quiz 453–5.
  141. Urheim S, Edvardsen T, Torp H, Angelsen B, Smiseth OA. Myocardial strain by Doppler echocardiography. Validation of a new method to quantify regional myocardial function. *Circulation* 2000;**102**:1158–64.
  142. Edvardsen T, Gerber BL, Garot J, Bluemke DA, Lima JA, Smiseth OA. Quantitative assessment of intrinsic regional myocardial deformation by Doppler strain rate echocardiography in humans: validation against three-dimensional tagged magnetic resonance imaging. *Circulation* 2002;**106**:50–6.
  143. Belohlavek M, Bartleson VB, Zobitz ME. Real-time strain rate imaging: validation of peak compression and expansion rates by a tissue-mimicking phantom. *Echocardiography* 2001;**18**:565–71.
  144. Kang SJ, Lim HS, Choi BJ, Choi SY, Hwang GS, Yoon MH et al. Longitudinal strain and torsion assessed by two-dimensional speckle tracking correlate with the serum level of tissue inhibitor of matrix metalloproteinase-1, a marker of myocardial fibrosis, in patients with hypertension. *J Am Soc Echocardiogr* 2008;**21**:907–11.
  145. Yingchoncharoen T, Agarwal S, Popovic ZB, Marwick TH. Normal ranges of left ventricular strain: a meta-analysis. *J Am Soc Echocardiogr* 2013;**26**:185–91.
  146. Phelan D, Collier P, Thavendiranathan P, Popovic ZB, Hanna M, Plana JC et al. Relative apical sparing of longitudinal strain using two-dimensional speckle-tracking echocardiography is both sensitive and specific for the diagnosis of cardiac amyloidosis. *Heart* 2012;**98**:1442–8.
  147. Weidemann F, Breunig F, Beer M, Sandstede J, Stork S, Voelker W et al. The variation of morphological and functional cardiac manifestation in Fabry disease: potential implications for the time course of the disease. *Eur Heart J* 2005;**26**:1221–7.
  148. Owan TE, Hodge DO, Herges RM, Jacobsen SJ, Roger VL, Redfield MM. Trends in prevalence and outcome of heart failure with preserved ejection fraction. *N Engl J Med* 2006;**355**:251–9.
  149. Tapp RJ, Sharp A, Stanton AV, O'Brien E, Chaturvedi N, Poulter NR et al. Differential effects of antihypertensive treatment on left ventricular diastolic function: an ASCOT (Anglo-Scandinavian cardiac outcomes trial) substudy. *J Am Coll Cardiol* 2010;**55**:1875–81.
  150. Lutas EM, Devereux RB, Reis G, Alderman MH, Pickering TG, Borer JS et al. Increased cardiac performance in mild essential hypertension. Left ventricular mechanics. *Hypertension* 1985;**7**:979–88.
  151. Cicala S, de Simone G, Roman MJ, Best LG, Lee ET, Wang W et al. Prevalence and prognostic significance of wall-motion abnormalities in adults without clinically recognized cardiovascular disease: the strong heart study. *Circulation* 2007;**116**:143–50.
  152. Di Bello V, Talini E, Dell'Omo G, Giannini C, Delle Donne MG, Canale ML et al. Early left ventricular mechanics abnormalities in prehypertension: a two-dimensional strain echocardiography study. *Am J Hypertens* 2010;**23**:405–12.
  153. Muiesan ML, Salvetti M, Rizzoni D, Monteduro C, Castellano M, Agabiti-Rosei E. Persistence of left ventricular hypertrophy is a stronger indicator of cardiovascular events than baseline left ventricular mass or systolic performance: 10 years of follow-up. *J Hypertens Suppl* 1996;**14**:S43–9.
  154. de Simone G, Izzo R, Chinali M, De Marco M, Casalnuovo G, Rozza F et al. Does information on systolic and diastolic function improve prediction of a cardiovascular event by left ventricular hypertrophy in arterial hypertension? *Hypertension* 2010;**56**:99–104.
  155. Appleton CP, Jensen JL, Hatle LK, Oh JK. Doppler evaluation of left and right ventricular diastolic function: a technical guide for obtaining optimal flow velocity recordings. *J Am Soc Echocardiogr* 1997;**10**:271–92.
  156. Nagueh SF, Appleton CP, Gillebert TC, Marino PN, Oh JK, Smiseth OA et al. Recommendations for the evaluation of left ventricular diastolic function by echocardiography. *Eur J Echocardiogr* 2009;**10**:165–93.
  157. Klein AL, Burstow DJ, Tajik AJ, Zachariah PK, Bailey KR, Seward JB. Effects of age on left ventricular dimensions and filling dynamics in 117 normal persons. *Mayo Clin Proc* 1994;**69**:212–24.
  158. Vanoverschelde JL, Raphael DA, Robert AR, Cosyns JR. Left ventricular filling in dilated cardiomyopathy: relation to functional class and hemodynamics. *J Am Coll Cardiol* 1990;**15**:1288–95.
  159. Wachtell K, Palmieri V, Gerds E, Bella JN, Aurigemma GP, Papademetriou V et al. Prognostic significance of left ventricular diastolic dysfunction in patients with left ventricular hypertrophy and systemic hypertension (the LIFE study). *Am J Cardiol* 2010;**106**:999–1005.
  160. Nagueh SF, Middleton KJ, Kopelen HA, Zoghbi WA, Quinones MA. Doppler tissue imaging: a non-invasive technique for evaluation of left ventricular relaxation and estimation of filling pressures. *J Am Coll Cardiol* 1997;**30**:1527–33.
  161. Rivas-Gotz C, Manolios M, Thohan V, Nagueh SF. Impact of left ventricular ejection fraction on estimation of left ventricular filling pressures using tissue Doppler and flow propagation velocity. *Am J Cardiol* 2003;**91**:780–4.
  162. Park JH, Marwick TH. Use and limitations of  $e'/e'$  to assess left ventricular filling pressure by echocardiography. *J Cardiovasc Ultrasound* 2011;**19**:169–73.
  163. Wang M, Yip G, Yu CM, Zhang Q, Zhang Y, Tse D et al. Independent and incremental prognostic value of early mitral annulus velocity in patients with impaired left ventricular systolic function. *J Am Coll Cardiol* 2005;**45**:272–7.
  164. Wang M, Yip GW, Wang AY, Zhang Y, Ho PY, Tse MK et al. Tissue Doppler imaging provides incremental prognostic value in patients with systemic hypertension and left ventricular hypertrophy. *J Hypertens* 2005;**23**:183–91.
  165. Dokainish H, Zoghbi WA, Lakkis NM, Ambriz E, Patel R, Quinones MA et al. Incremental predictive power of b-type natriuretic peptide and tissue Doppler echocardiography in the prognosis of patients with congestive heart failure. *J Am Coll Cardiol* 2005;**45**:1223–6.
  166. Sharp AS, Tapp RJ, Thom SA, Francis DP, Hughes AD, Stanton AV et al. Tissue Doppler  $e'/e'$  ratio is a powerful predictor of primary cardiac events in a hypertensive population: an ASCOT substudy. *Eur Heart J* 2010;**31**:747–52.
  167. Mancia G, Fagard R, Narkiewicz K, Redon J, Zanchetti A, Bohm M et al. 2013 ESH/ESC guidelines for the management of arterial hypertension: the task force for the management of arterial hypertension of the European Society of Hypertension (ESH) and of the European Society of Cardiology (ESC). *Eur Heart J* 2013;**34**:2159–219.
  168. Verdecchia P, Angeli F, Achilli P, Castellani C, Broccatelli A, Gattobigio R et al. Echocardiographic left ventricular hypertrophy in hypertension: marker for future events or mediator of events? *Curr Opin Cardiol* 2007;**22**:329–34.
  169. Gosse P. Left ventricular hypertrophy as a predictor of cardiovascular risk. *J Hypertens Suppl* 2005;**23**:S27–33.
  170. Nadour W, Biederman RW. Is left ventricular hypertrophy regression important? Does the tool used to detect it matter? *J Clin Hypertens (Greenwich)* 2009;**11**:441–7.
  171. Cuspidi C, Sala C, Negri F, Mancia G, Morganti A. Prevalence of left-ventricular hypertrophy in hypertension: an updated review of echocardiographic studies. *J Hum Hypertens* 2012;**26**:343–9.
  172. St John Sutton M, Pfeffer MA. Prevention of post-infarction left ventricular remodeling by ace-inhibitors. *Cardiology* 1994;**39**:27–30.
  173. Kramer DG, Trikalinos TA, Kent DM, Antonopoulos GV, Konstam MA, Udelson JE. Quantitative evaluation of drug or device effects on ventricular remodeling as predictors of therapeutic effects on mortality in patients with heart failure and reduced ejection fraction: a meta-analytic approach. *J Am Coll Cardiol* 2010;**56**:392–406.
  174. Kirkpatrick JN, Vannan MA, Narula J, Lang RM. Echocardiography in heart failure: applications, utility, and new horizons. *J Am Coll Cardiol* 2007;**50**:381–96.
  175. Solomon SD, Janardhanan R, Verma A, Bourgoun M, Daley WL, Purkayastha D et al. Effect of angiotensin receptor blockade and antihypertensive drugs on diastolic function in patients with hypertension and diastolic dysfunction: a randomised trial. *Lancet* 2007;**369**:2079–87.
  176. Wachtell K, Bella JN, Rokkedal J, Palmieri V, Papademetriou V, Dahlof B et al. Change in diastolic left ventricular filling after one year of antihypertensive treatment: the Losartan intervention for endpoint reduction in hypertension (LIFE) study. *Circulation* 2002;**105**:1071–6.
  177. Greenland P, Alpert JS, Beller GA, Benjamin EJ, Budoff MJ, Fayad ZA et al. 2010 ACCF/AHA guideline for assessment of cardiovascular risk in asymptomatic adults: a report of the American College of Cardiology Foundation/American Heart Association Task force on practice guidelines. *Circulation* 2010;**122**:e584–636.
  178. American College of Cardiology Foundation Appropriate Use Criteria Task Force, American Society of Echocardiography, American Heart Association, American Society of Nuclear Cardiology, Heart Failure Society of America, Heart Rhythm Society et al. ACCF/AHA/ASA/ASNC/HFSA/HR/SCAI/SCCM/SCCT/SCMR 2011 appropriate use criteria for echocardiography. A report of the American College of Cardiology Foundation appropriate use criteria task force, American Society of Echocardiography, American Heart Association, American Society of Nuclear Cardiology, Heart Failure Society of America, Heart Rhythm Society, Society for Cardiovascular Angiography and Interventions, Society of Critical Care Medicine, Society of Cardiovascular Computed Tomography, and Society for Cardiovascular Magnetic Resonance Endorsed by the American College of Chest Physicians. *J Am Coll Cardiol* 2011;**57**:1126–66.
  179. Chobanian AV, Bakris GL, Black HR, Cushman WC, Green LA, Izzo JL Jr et al. The Seventh Report of the Joint National Committee on prevention, detection, evaluation, and treatment of high blood pressure: The JNC 7 report. *JAMA* 2003;**289**:2560–72.

180. Nunez E, Arnett DK, Benjamin EJ, Oakes JM, Liebson PR, Skelton TN. Comparison of the prognostic value of left ventricular hypertrophy in African-American men versus women. *Am J Cardiol* 2004;**94**:1383–90.
181. Okin PM, Roman MJ, Lee ET, Galloway JM, Howard BV, Devereux RB. Combined echocardiographic left ventricular hypertrophy and electrocardiographic ST depression improve prediction of mortality in American Indians: The strong heart study. *Hypertension* 2004;**43**:769–74.
182. Rodriguez CJ, Lin F, Sacco RL, Jin Z, Boden-Albala B, Homma S et al. Prognostic implications of left ventricular mass among Hispanics: the Northern Manhattan study. *Hypertension* 2006;**48**:87–92.
183. Verdecchia P, Carini G, Circo A, Dovellini E, Giovannini E, Lombardo M et al. Left ventricular mass and cardiovascular morbidity in essential hypertension: The MAVI study. *J Am Coll Cardiol* 2001;**38**:1829–35.
184. Lapu-Bula R, Ofili E. From hypertension to heart failure: role of nitric oxide-mediated endothelial dysfunction and emerging insights from myocardial contrast echocardiography. *Am J Cardiol* 2007;**99**:7D–14D.
185. Picano E, Palinkas A, Amyot R. Diagnosis of myocardial ischemia in hypertensive patients. *J Hypertens* 2001;**19**:1177–83.
186. Fragasso G. Detection of coronary disease in patients with hypertension: a resolved issue? *J Clin Hypertens (Greenwich)* 2000;**2**:210–4.
187. Cortigiani L, Rigo F, Galderisi M, Gherardi S, Bovenzi F, Picano E et al. Diagnostic and prognostic value of Doppler echocardiographic coronary flow reserve in the left anterior descending artery in hypertensive and normotensive patients [corrected]. *Heart* 2011;**97**:1758–65.
188. Schmieder RE, Martus P, Klingbeil A. Reversal of left ventricular hypertrophy in essential hypertension. A meta-analysis of randomized double-blind studies. *JAMA* 1996;**275**:1507–13.
189. Devereux RB, Palmieri V, Sharpe N, De Quattro V, Bella JN, de Simone G et al. Effects of once-daily angiotensin-converting enzyme inhibition and calcium channel blockade-based antihypertensive treatment regimens on left ventricular hypertrophy and diastolic filling in hypertension: the prospective randomized enalapril study evaluating regression of ventricular enlargement (PRESERVE) trial. *Circulation* 2001;**104**:1248–54.
190. Okin PM, Devereux RB, Nieminen MS, Jern S, Oikarinen L, Viitasalo M et al. Electrocardiographic strain pattern and prediction of cardiovascular morbidity and mortality in hypertensive patients. *Hypertension* 2004;**44**:48–54.
191. Liebson PR, Grandits GA, Dianzumba S, Prineas RJ, Grimm RH Jr, Neaton JD et al. Comparison of five antihypertensive monotherapies and placebo for change in left ventricular mass in patients receiving nutritional-hygienic therapy in the treatment of mild hypertension study (TOMHS). *Circulation* 1995;**91**:698–706.
192. Gottdiener JS, Reda DJ, Massie BM, Materson BJ, Williams DW, Anderson RJ. Effect of single-drug therapy on reduction of left ventricular mass in mild to moderate hypertension: comparison of six antihypertensive agents. The Department of Veterans Affairs Cooperative Study Group on antihypertensive agents. *Circulation* 1997;**95**:2007–14.
193. Gottdiener JS, Reda DJ, Williams DW, Materson BJ, Cushman W, Anderson RJ. Effect of single-drug therapy on reduction of left atrial size in mild to moderate hypertension: comparison of six antihypertensive agents. *Circulation* 1998;**98**:140–8.
194. National Institute for Health and Care Excellence (NICE). *Hypertension: Clinical Management of Primary Hypertension in Adults; Clinical Guidelines (CG127)*. 2011.
195. Valocik G, Kamp O, Mannaerts HF, Visser CA. New quantitative three-dimensional echocardiographic indices of mitral valve stenosis: new 3D indices of mitral stenosis. *Int J Cardiovasc Imaging* 2007;**23**:707–16.
196. Harada K, Saitoh T, Tanaka J, Shibayama K, Berdejo J, Shiota T. Valvuloarterial impedance, but not aortic stenosis severity, predicts syncope in patients with aortic stenosis. *Circ Cardiovasc Imaging* 2013;**6**:1024–31.
197. Ha JW, Juracan EM, Mahoney DW, Oh JK, Shub C, Seward JB et al. Hypertensive response to exercise: a potential cause for new wall motion abnormality in the absence of coronary artery disease. *J Am Coll Cardiol* 2002;**39**:323–7.
198. Fragasso G, Lu C, Dabrowski P, Pagnotta P, Sheiban I, Chierchia SL. Comparison of stress/rest myocardial perfusion tomography, dipyridamole and dobutamine stress echocardiography for the detection of coronary disease in hypertensive patients with chest pain and positive exercise test. *J Am Coll Cardiol* 1999;**34**:441–7.
199. Schillaci G, De Simone G, Reboldi G, Porcellati C, Devereux RB, Verdecchia P. Change in cardiovascular risk profile by echocardiography in low- or medium-risk hypertension. *J Hypertens* 2002;**20**:1519–25.
200. Yoon SS, Burt V, Louis T, Carroll MD. Hypertension among adults in the united states, 2009–2010. *NCHS Data Brief* 2012;**107**:1–8.
201. Gottdiener JS, Bednarz J, Devereux R, Gardin J, Klein A, Manning WJ et al. American society of echocardiography recommendations for use of echocardiography in clinical trials. *J Am Soc Echocardiogr* 2004;**17**:1086–119.
202. Douglas PS, DeCara JM, Devereux RB, Duckworth S, Gardin JM, Jaber WA et al. Echocardiographic imaging in clinical trials: American Society of Echocardiography Standards for echocardiography core laboratories: endorsed by the American College of Cardiology Foundation. *J Am Soc Echocardiogr* 2009;**22**:755–65.
203. Galderisi M, Henein MY, D'Hooge J, Sicari R, Badano LP, Zamorano JL et al. Recommendations of the European Association of Echocardiography: how to use echocardiography in clinical trials: different modalities for different purposes. *Eur J Echocardiogr* 2011;**12**:339–53.