

# Wireless synchronisation for low cost wireless sensor networks using DCF77

Joannes I. Laveyne,  
Power-Link, Ghent University  
Belgium  
joannes.laveyne@ugent.be

Lieven Vandeveldde  
Department of Electrical Energy,  
Systems and Automation Ghent  
University  
Belgium

Greet Van Eetvelde  
Department of Environmental and  
Spatial Management Ghent  
University  
Belgium

**Abstract**—Wireless Sensor Networks (WSN) consist out of multiple end nodes containing sensors and one or more coordinator nodes which poll and command the end nodes. WSN can prove very efficient in distributed energy data acquisition, e.g. for phasor or power measurements. These types of measurements however require relatively tight synchronisation, which is sometimes difficult to achieve for low-cost WSN. This paper explores the possibility of a low-cost wireless synchronization system using the DCF77 long wave time signal to achieve sub-millisecond synchronisation accuracy. The results are compared to conventional GPS based synchronisation. As a practical example, the implementation of the described synchronisation method is proposed for a non-contact electrical phase identifier, which uses synchronised current measurements to distinguishing between the different phases in an unmarked electrical distribution grid.

**Keywords**—energy monitoring, data-acquisition, wireless sensor networks, wireless synchronisation

## I. INTRODUCTION

Accurate time synchronization is extremely important in Wireless Sensor Networks (WSN) [1], not only for setting up efficient communication scheduling between nodes [2] but also for execution of certain tasks such as coordinated movement of synchronised measurements. It is however a challenge to achieve good synchronization using low-cost transceiver hardware due to several non-deterministic delays in the firmware or hardware of the transceivers and environmental influences such as radio signal reflections. In Wide Area Measurement Systems (WAMS) the signal offered by Global Positioning System (GPS) satellites is often used [3] as this signal provides both time and position, enabling the receiver to achieve an accurate synchronisation [4]. However, GPS reception in buildings is often limited or not available, and while the cost of GPS receivers has decreased it is often still not viable to implement one on each node of a low cost WSN. Long wave signals are less prone to reflection by obstacles and their receivers only cost a fraction of their GPS counterparts. They also require less complex host controller hardware and firmware.

## II. WIRELESS SYNCHRONISATION

Assuming each node has its own timekeeping system, there are two main methods of achieving synchronisation between nodes [5]. The first one is local synchronisation in which the nodes synchronize their local time with the time kept by neighbouring nodes, thereby cancelling out clock drift and offset. The second method is global synchronisation in which a central node broadcasts a synchronisation signal throughout the network, and all nodes synchronise their clock to this signal.

The main challenges in both methods are non-deterministic delays in the firmware of the host controller, the hardware of the wireless transceivers and in the propagation of the wireless signal. According to [5] the total delay can be split up in four components

- Send time: the time it takes the transmitting host controller to assemble the time packet and dispatch it to the transceiver radio.
- Access time: the time the radio requires to transpose the time packet onto the physical wireless layer.
- Propagation time: the time it takes for the packet to travel from the transmitting radio through the physical medium to the receiving radio.
- Receiving time: the time it takes the receiving radio to transcode the time packet and dispatch it to the receiving host controller.

All these components include non-deterministic delays which can hamper proper synchronisation. The synchronisation system presented in this paper eliminates or compensates for these non-deterministic delays by abandoning the packetisation of the time signal and focussing on the signal transmitted through the physical medium. It uses a simplified variation on the Reference Broadcast Synchronisation (RBS) method, in which a central node broadcasts a beacon signal containing no actual timing information [6]. Instead, the arrival of the beacon on the receiving radio acts as the synchronisation signal. The presented system relies on implicit timing assumptions between nodes, requiring no additional communication or even

avoiding the need for a two-way transceiver. Only relative timing synchronisation is required, eliminating the problem of possible clock drift in the beacon transmitter. When the nodes are in relative proximity to one another, the propagation delays can be assumed to be similar.

### III. THE DCF77 TIME SIGNAL

The DCF77 signal is a so called time signal broadcasted on a longwave 77.5 kHz carrier. Time signals are used for clock distribution and synchronisation, and the DCF77 signal digitally encodes time and date information on its analog carrier wave. The DCF77 transmitter is located in the German municipality of Mainflingen and is operated by the Physikalisch-Technische Bundesanstalt (PTB), Germany's national physics laboratory. The PTB is tasked by the German government to keep and distribute the official German legal time, and employs four atomic clocks for this purpose [7]. This time signal is also used to create the Coordinated Universal Time or UTC, the primary international time standard.

With 50 kW of transmit power, the DCF77 time signal can be reliably received at ranges up to 2,000 kilometres from the transmission site. The transmitter has a very high uptime, with a yearly temporal availability typically above 99,9% [8]. Combined with the ease by which the time information can be decoded, this has made the DCF77 signal a popular way of wireless synchronising clocks throughout Europe.

Time information is encoded on the 77.5 kHz carrier wave in two ways: by amplitude modulation, or by phase modulation. Only the former is discussed in this paper. In the amplitude modulation scheme, the time information is binary encoded, with one bit being transmitted at the beginning of every second. To denote a binary zero, the power of the carrier wave is reduced to 15% of its original value for the duration of 0.1 second. To denote a binary one, this reduction lasts for 0.2 second. The last second of every minute omits this power reduction. Of the 59 transmitted bits per minute, the first 20 contain weather and status information, followed by 15 bits of time information and the remaining 24 bits containing the date.

Because of the low bitrate and timing resolution, decoding the time signal is of no use to sensor networks requiring sub-second synchronisation. However, because of the high accuracy of the time signal and its carrier wave, the start of the carrier wave power reduction is very precise and easily detected, making it a very interesting choice for synchronisation in low-cost WSN.

## IV. EXPERIMENTAL TEST SET-UP

### A. Test Set-up

In order to test whether the DCF77 signal is usable for the synchronisation of wireless nodes, an experimental set-up was made with three DCF77 receivers placed in different, real-life environments. 100 meters of standard UTP wiring with identical electrical characteristics are run between each receiver and one digital oscilloscope, positioned in a central point. When a DCF77 timing bit is received on the receivers, this is converted to an electrical pulse and transmitted through the wiring to the oscilloscope. Here, the time delay between the pulses, representing the timing bits received by each individual receiver, is measured. Several measurements are made and averaged. Receivers 2 and 3 are then placed in different environments, with receiver 1, placed outside in an open field and always between 150 and 200 meter apart from the other receivers, acting as a reference. Figure 1 shows an example of a DCF77 timing bit received by all three receivers. Note that the receivers display an unwanted ringing effect, but by using peak detection synchronisation can still be achieved.

In the first test, receiver 2 is placed on a rooftop of an office building approximately 6 meters high, with no nearby obstacles exceeding the height of the receiver. Receiver 3 is placed at ground level in an office space inside this building, nearby a window. Figure 2 shows a measurement of this set-up, with the time delay between receiver 1 and 2 approximating 1.06 milliseconds. The averaged delay between receiver 1 and 2 nears 0.7 milliseconds, the delay between receiver 1 and 3 averages 0.9 milliseconds.

In a second test, receiver 2 was placed more centrally inside a ground level office space. Average timing delays stayed more or less constant. However, receiver 2 now picked up several reflections, as shown in Figure 3. Because other receivers do not pick up these reflections, accurate synchronisation is still possible.

In a third test, receiver 3 was moved on the rooftop to a location where metal air ducts were blocking the northeast view, where the DCF77 transmitter is located. Average timing delay again stayed roughly constant, but the reception quality of the DCF77 timing bits decreased rapidly and became indeterministic, as shown in figure 4. In most cases, synchronisation was still possible but at a reduced speed: sometimes it took several seconds before a usable timing bit was received by the transmitter.

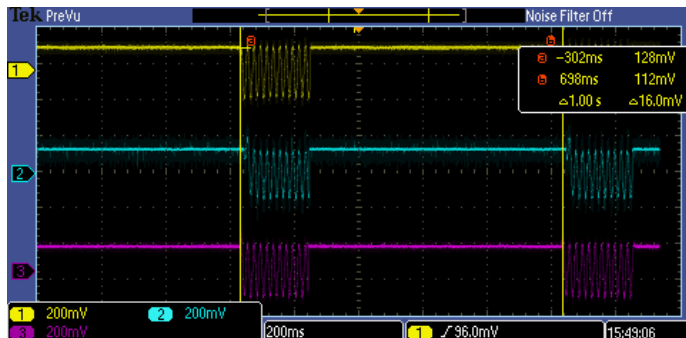

FIGURE 1: DCF77 SIGNAL RECEIVED BY MULTIPLE RECEIVERS

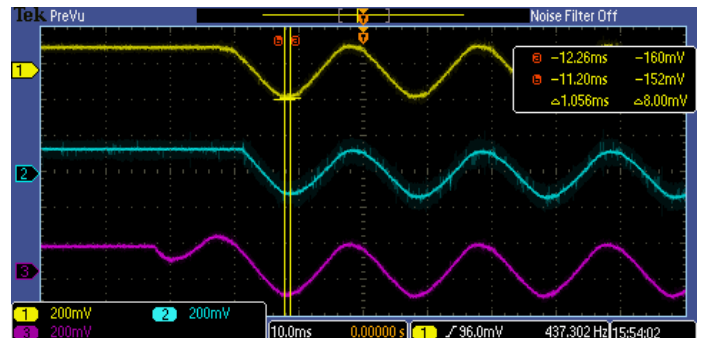

FIGURE 2: TIME DELAY BETWEEN TWO RECEIVED DCF77 BEACONS

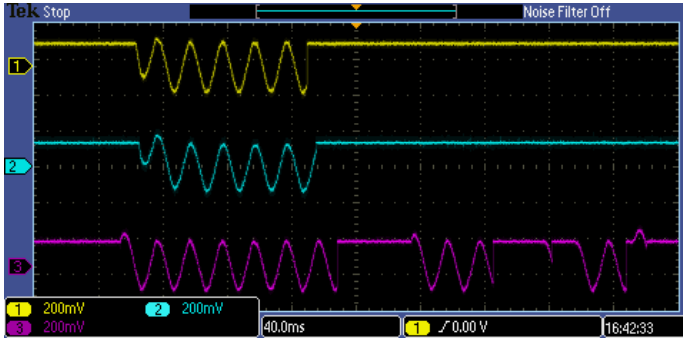

FIGURE 3: REFLECTIONS PICKED UP BY RECEIVER #3

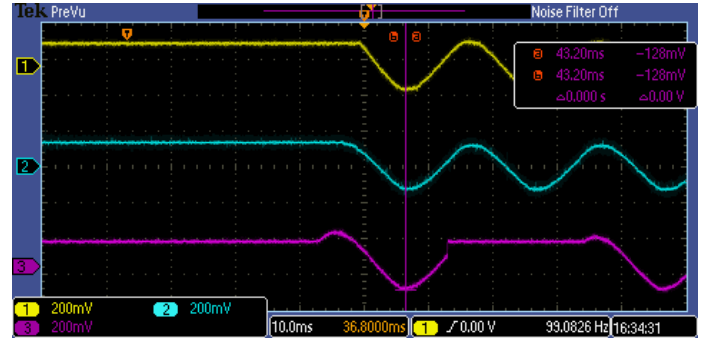

FIGURE 4: UNRELIABLE DCF77 RECEPTION BY RECEIVER #3

Three additional tests were then run whereby the receivers were placed in environments such as a transformer cabin or second floor office spaces, but the results were comparable with tests 1 and 2.

Averaging the results of all tests yield a discrepancy between the receivers of on average 0.67 milliseconds. This difference can be attributed to several sources, such as signal reflection or distortion of the carrier wave by nearby electronic devices, or by non-linearities in the analog electronics of each receiver.

By using the DCF77 time signal, on average sub-millisecond precision can be achieved between individual receivers located up to 200 meters apart. For most low cost WSN, this provides sufficient timing accuracy.

#### B. Comparison with GPS synchronisation

The experimental set-up described above resulted in a relative synchronisation accuracy of on average 0.67 milliseconds. Compared to GPS synchronisation, which is one of the most commonplace methods of achieving wireless synchronisation, this is significant less accurate. Synchronisation between different GPS receivers can be as accurate as 4 to 10 nanoseconds [9].

On the other hand, GPS receivers are much more expensive with prices generally above €25 for small quantities, while a DCF77 receiver only costs around €2. They also require more complex host controller and additional firmware to parse the digital datastream coming from the GPS receivers. With a DCF77 receiver, a microcontroller with an external interrupt

input is sufficient. For low-cost WSN requiring millisecond precision, DCF77 would seem to be a more economic choice for wireless synchronisation.

Next to economic aspects, power requirements are very important for the reliable operation of WS, where the nodes are often battery powered. GPS receivers and their host controllers have higher power requirements, necessitating larger batteries or more frequent battery recharging.

Another drawback of the GPS method is the relatively large Time To First Fix (TTFF): the time it takes for the GPS receiver to synchronise for the first time with the GPS satellite constellation. This can take from many seconds up to several minutes. With a DCF77 receiver, synchronisation is instant, making mobile and intermittent use much more practical.

A limited comparison between synchronisation based on DCF77 versus GPS is shown in Table I. Summarizing, synchronisation based on DCF77 would seem to be a favourable choice for low-cost WSN with synchronisation accuracy requirements of 1 millisecond or less.

#### V. ELECTRICAL PHASE IDENTIFIER

Electrical phase identification is required for common tasks such as balanced connection of single phase loads on a three phase system, single phase energy monitoring or for safety reasons. It is however possible that phase wires are unmarked or share sheathing of the same colour, complicating the identification of the different electrical phases. Devices modulating a high frequency identification signal onto the phase wires are commercially available, but require electrical

TABLE I. COMPARISON BETWEEN DCF77 AND GPS SYNCHRONISATION

Comparison between DCF77 and GPS synchronisation	
DCF77	GPS
Very low cost	Medium to high cost
Sub-millisecond relative timing accuracy	Sub-microsecond relative timing accuracy
Second-based absolute timing accuracy	Sub-second absolute timing accuracy
Adequate reception in-doors	Difficult reception with no line of sight to GPS satellites
Easily integrated	Integration requires more complex firmware and powerful microcontrollers
Extremely low power requirements	Medium to high power requirements
TTFF in seconds	TTFS in seconds to minutes

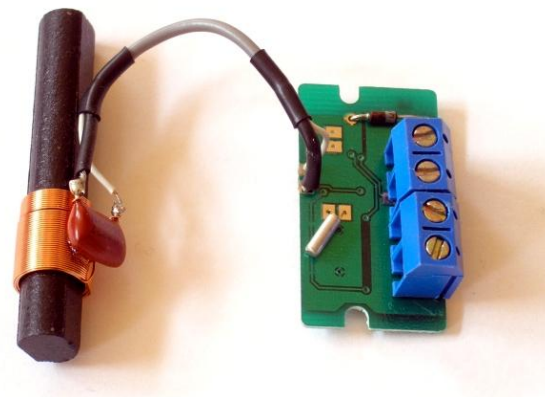

FIGURE 5: A LOW COST DCF77 RECEIVER

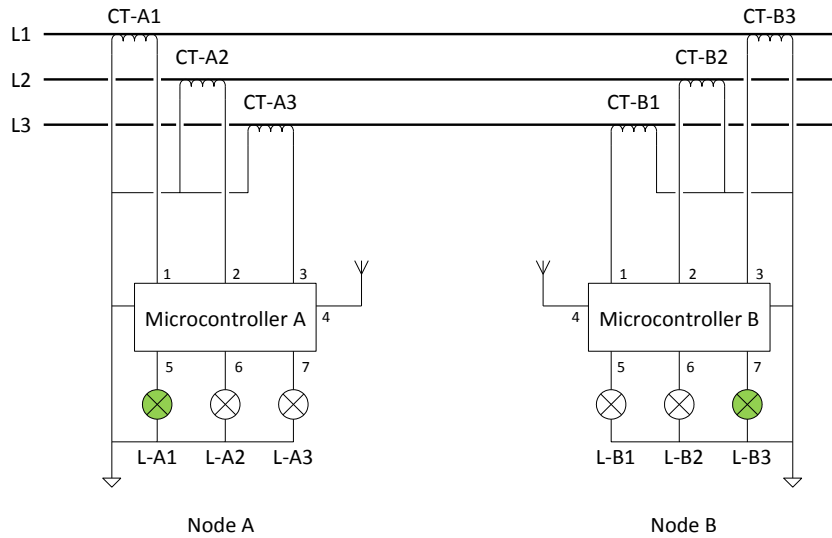

FIGURE 6: ELECTRICAL PHASE IDENTIFICATION BASED ON DCF77

contact to the wires. Sometimes electrical contact is not possible or safe, e.g. on live wires.

As a practical implementation of the DCF77 based wireless synchronisation discussed in this paper, a two-nodes non-contact phase identification system is proposed. It employs non-contact current measurements, e.g. through the use of current transducers (CT) such as the LEM AT-B5 module, a DCF77 receiver and a low-cost microcontroller with 4 external interrupts, e.g. the ATmega8515.

The LEM AT-B5 module is a CT based on a Hall-effect sensor. It outputs a 0V to 5V signal based on the RMS value of the current flowing through the conductor where it is clipped on. In the proposed phase identification system, each measurement node is equipped with three of these modules to be clipped on the three phases of a typical low-voltage electrical grid.

The signal outputs of CTs CT-A1 to CT-A3 are connected to external interrupt pins 1 through 3 of microcontroller A, the signal outputs of LEM modules CT-B1 to CT-B3 are connected to external interrupt pins 1 to 3 of microcontroller B.

The DCF77 receiver outputs a 5V pulse whenever a DCF77 timing beacon is received. The output of each receiver is connected to the external interrupt input 4 of each microcontroller. Additionally, three LEDs numbered L-A1 to L-A3 are connected to output pins 5 to 7 of microcontroller A, and three LEDs numbered L-B1 to L-B3 are connected to output pins 5 to 7 of microcontroller B. These LEDs correspond to each respective input pin.

The microcontroller is programmed to initiate an interrupt routine whenever external interrupt pin 4, to which the DCF77 receiver is attached to, is pulled high. When this routine is activated, it awaits the first zero-crossing on one of the other external interrupt inputs. The LED output pin correlating to the input pin on which the first zero-crossing is detected is set high.

Because all nodes are synchronised on the same DCF77 pulse, only the LED outputs corresponding to the same input pin and, consequently, the same phase wire will be lit, making phase identification possible.

In the example in Figure 6, LEDs L-A1 and L-B3 are lighted simultaneously, indicating CTs CT-A1 and CT-B3 are connected to the same phase wire.

While the simple example proposed above perhaps has little practical value, it serves to illustrate the possibilities of wirelessly synchronising different nodes of a WSN by using DCF77. The same principle can be used for other tasks, such as synchronising data-acquisition between measurement nodes of a WSN, initiating simultaneous movement of actuators or switching certain circuits on and off at the same time.

## VI. CONCLUSIONS

In this paper the feasibility of using DCF77 receivers to achieve wireless synchronisation in low-cost WSN is explored. The proposed method removes the need for complex transceiver and host controller hardware and firmware present in other wireless synchronisation systems such as GPS, thereby eliminating a number of non-deterministic delays present in other wireless synchronisation systems. The DCF77 based system also features a lower cost and improved battery life compared to the GPS alternative.

An experimental test-setup was built in order to validate the proposed system, and the results were compared to these of a GPS-based alternative. Synchronisation accuracy of the GPS-based system is vastly greater than the proposed DCF77 system, but the latter still achieves a synchronisation accuracy that is usable for many low-cost WSN.

Finally, a practical implementation of the synchronisation system was presented to illustrate the conceptual system.

## REFERENCES

- [1] I. F. Akyildiz, W. Su, Y. Sankarasubramaniam, and E. Cayirci. Wireless sensor networks: a survey. *Computer Networks*, Volume 38, Issue 4, 15 March 2002, p. 393–422.
- [2] Y.-W. Hong, A. Scaglione. On multiple access for distributed dependent sources: a content-based group testing approach. Presented at the IEEE Inf. Theory Workshop, San Antonio, TX, 2004
- [3] W. Shaobu, G. Wenzhong, W. Jianhui, and L. Jin. Synchronized Sampling Technology-Based Compensation for Network Effects in WAMS Communication. *IEEE Transactions on Smart Grid*, Volue 3 Issue 2, 2012, p. 837-845
- [4] J. Mannermaa, K. Kalliomaki, T. Mansten, and S. Turunen, Timing performance of various GPS receivers. *Proc. Joint Meeting Eur. Freq. Time Forum and IEEE Int. Freq. Control Symp.*, Apr. 1999, pp. 287–290
- [5] Sivrikaya, F.; Yener, B. Time synchronization in sensor networks: A Survey, *IEEE Network*, Volume 18, Issue 4, p. 45 – 50
- [6] J. Elson, L. Girod, D. Estrin. Fine-grained network time synchronization using reference broadcasts. *Usenix association proceedings of the 5th Symposium on Operation Systems Design and Implementation*, Boston, 2002, p. 147-163
- [7] Physikalisch-Technische Bundesanstalt (PTB), Realisation of Legal Time in Germany
- [8] Physikalisch-Technische Bundesanstalt (PTB), Das abwechslungsreichste Radioprogramm der Welt. *PTB Pressemitteilung*, 2003
- [9] H. G. Berns, R. J. Wilkes, GPS Time Synchronization System for K2K. *Real Time Conference*, Santa Fe 1999