

PAPER REF: 2938

## RESIDUAL STRAIN MONITORING DURING COMPOSITE MANUFACTURING

Nicolas Lammens<sup>1(\*)</sup>, Damien Kinet<sup>2</sup>, Karima Chah<sup>2</sup>, Geert Luyckx<sup>1</sup>, Christophe Caucheteur<sup>2</sup>, Joris Degrieck<sup>1</sup>

<sup>1</sup>Department of Materials Science & Engineering, UGent, Ghent, Belgium

<sup>2</sup>Department of Electromagnetism and telecommunications, UMon, Mons, Belgium

(\*)Email: Nicolas.Lammens@ugent.be

### ABSTRACT

This work explores a new possibility in accurate measurement of multi-axial residual strains during the production of composite structures. It investigates the usability of the polarization dependent loss (PDL) of an optical fibre Bragg grating as a sensitive indicator of multi-axial residual strains. The experimental work presented is done on a cross-ply carbon fibre reinforced polymer fabricated using an autoclave cycle.

**Keywords:** optical fiber sensing, Bragg sensors, polarization dependent loss (PDL), residual strain sensing

### INTRODUCTION

While composite materials are increasingly being used as replacements to traditional steel, their complex failure mechanics require more sophisticated design and maintenance procedures. In order to avoid significant down-time of constructions for maintenance, embedded sensors can provide a continuous way of monitoring the health of the structure. Within this area of structural health monitoring (SHM), optical fibers are often very attractive candidates as sensing systems. Their small dimensions and immunity to electromagnetic interference allow them to be embedded inside the composite structure and used in circumstances where other sensors would fail (such as a radioactive reactor where traditional strain gauges fail after a short time). Additionally, when optical fiber Bragg grating sensors are used as sensor, the measured parameter is encoded as a wavelength, and thus insensitive to drift over time. Finally, when embedded, a Bragg sensor is capable of providing multi-axial strain measurements. This multi-axial information is very useful when monitoring anisotropic structures such as composite materials.

While Bragg gratings are very sensitive to axial strains, transverse strains can only be detected once a certain threshold is overcome. Below this threshold, traditional amplitude measurements are incapable of detecting the transverse strains and axial accuracy is compromised.

A common approach to overcoming this threshold is through the use of polarization maintaining fibers (PM), in which an inherent transverse strain overcomes the initial threshold, thereby enabling the immediate accurate measurement of axial and transverse strains. Unfortunately, using this type of fiber requires the external transverse load to be aligned with the inherent strains in order not to cancel out each other. This requires very precise orientation during production, and entails careful manual manipulation.

While these PM-fibers might work sufficiently well within a research-facility, the manual labor involved in orienting a PM fiber is not industrially feasible.

This paper will present an alternative technique known as polarization dependent loss, in order to accurately measure small transverse strains, using normal (non-PM) optical fiber Bragg gratings. The paper covers the sensing and detection principle of Bragg gratings and Polarization Dependent Loss (PDL) measurements. The usability of PDL is illustrated on process monitoring of cross-ply carbon fiber composite laminates. A comparison is made between traditional amplitude measurements, and the new PDL approach.

## OPTICAL FIBER SENSING

Optical fibre sensors are ideal candidates as monitoring systems in composite structures. Their small size (the smallest optical fibre commercially sold only has a diameter of 50 micron) allow them to be embedded in a structure without significantly disturbing the part, while it's electromagnetic immunity allows it to be used in situations where strong radiation could disturb other sensors. The sensing capabilities of optical fibres come from sending light through the optical fibre and studying how it interacts with the fibre. Parameters such as strain, temperature, and chemical reactions ... can alter the way light travels through the fibre, resulting in a sensor for that parameter. Many different methods exist in optical fibre sensing, both distributed (e.g. Brillouin and/or Raman scattering) and localized (e.g. Bragg sensors). This paper will not expand on the different methodologies and their merits. This work shall from here on focus solely on optical fibre Bragg gratings (FBG) as a sensing-technology.

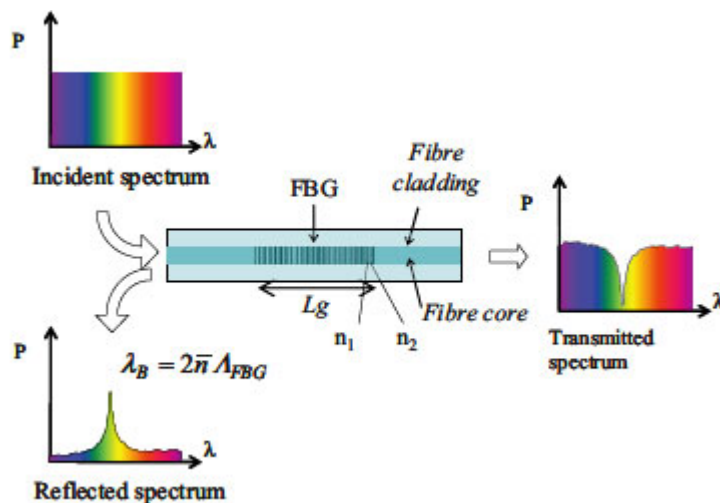

Figure 1: Principal of optical fibre Bragg grating (Voet 2011)

A fibre Bragg grating is a localized periodic modification (period or pitch  $\Lambda$ ) of the refractive index ( $n$ ) of an optical fibre (Figure 1). When launching a broadband light signal in the optical fibre, part of the spectrum gets reflected at the Bragg grating, with the central wavelength of the reflection determined by the Bragg-wavelength:

$$\lambda_B = 2n\Lambda \quad (1)$$

Obviously, when the optical fibre gets stretched, the grating pitch will change, and so will the reflected wavelength, resulting in a sensor for axial strains (and transverse strains via the Poisson effect). Less obvious is the sensitivity of the refractive index  $n$  to strain, called the strain-optic effect. This strain-optic effect is sensitive to all strain field components, including transverse strain. A change in transverse strain field will create to orthogonal polarization

directions within the optical fibre, each with a different refractive index. Coupling light into such an optical fibre, will force the light to follow one of both orthogonal polarization directions. Depending on the polarization of the light, a different refractive index will exist, leading a total of two (one for each polarization direction) different reflected wavelengths (called birefringence) in a FBG. Finally, through thermal expansion, an optical fibre is also sensitive to temperature. These sensitivities can be summarized in formulas as (Voet, Luyckx et al. 2010) (assuming a centre-strain approximation):

$$\frac{\Delta\lambda_{B,1}}{\lambda_{B,1}} = \varepsilon_3 - \frac{n^2}{2} (p_{11}\varepsilon_1 + p_{12}[\varepsilon_2 + \varepsilon_3]) + \beta\Delta T \quad (2)$$

$$\frac{\Delta\lambda_{B,2}}{\lambda_{B,2}} = \varepsilon_3 - \frac{n^2}{2} (p_{11}\varepsilon_2 + p_{12}[\varepsilon_1 + \varepsilon_3]) + \beta\Delta T \quad (3)$$

The parameters  $p_{11}$  and  $p_{12}$  are called the ‘strain-optic coefficients’ and are determined by the composition of the silica used in the fibre, the strain  $\varepsilon_3$  is directed along the axis of the optical fiber, while  $\varepsilon_1$  and  $\varepsilon_2$  are transverse strains.

As can be seen from (2) – (3), a difference in both transverse strains will lead to a birefringence at the position of the FBG. Note that these strains are those found in the core of the optical fibre. In order to determine the strains in the composite structure, a transfer matrix needs to be used. Equations (2) – (3) would, at first glance, also suggest that an optical fibre is instantaneously sensitive to transverse strains, and detection capabilities are only limited by the accuracy of the read-out equipment. Unfortunately, this is not the case.

The equations (2)-(3) determines the shift of the central wavelength of each reflected peak. Due to the finite bandwidth of these peaks however, at small separations of the central wavelength, the flanks of both peaks still overlap. In normal interrogation equipment, the detector is (intentionally) insensitive to polarization, and only detects the total amount of light. Therefore, if the peaks are not sufficiently separated, the flanks will combine and create a false, averaged detected peak. Even in the initial stages where peak separation becomes visible, the flanks interfere with the reading, resulting in incorrect peak detections. Fully accurate peak detection can only start when the peaks are fully separated. Such a level of peak separation will not occur in normal cure cycles, and usually even the first hints of peak separation will only start showing at the end of the cooling cycle. The results from a normal FBG interrogation system will therefore be insufficient for transverse residual strain monitoring when using conventional Bragg gratings.

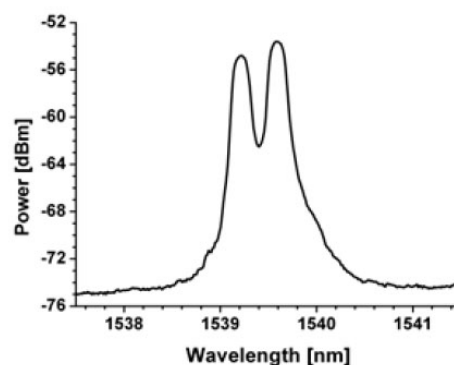

Figure 2: Reflection spectrum of a PM-fibre (Luyckx 2009)

One possible solution to this problem is the use of polarization maintaining (PM) fibre. In such fibres two polarization axes are deliberately created during their production of the fibre with a difference in the refractive index along both axes – these fibres are also known as high-

birefringence of HiBi. In the case of an FBG, this leads to full peak separation of the Bragg spectrum even in the absence of external loads (Figure 2). While these fibres are capable of sensing transverse strains earlier during the curing cycle, they have significant downsides. Any type of PM fibre will require the knowledge of the exact embedding orientation, in order to interpret the results (Chehura, Ye et al. 2004). This requires careful manual placement of the fibres during production cycle (not industrially feasible) or specialized equipment, which can detect the fibre orientation after curing (expensive and impractical for larger structures). Additionally, when stress-applying parts (SAP) are used in order to create a PM-fibre, interpreting the results is difficult since the exact properties of the SAP's are usually unknown to the end-user.

## **POLARIZATION DEPENDENT LOSS**

A solution where standard (non-PM) optical fibres can be used is to exploit the fact that both peaks originate from a different polarization direction. This can be achieved by measuring the polarization dependent loss (PDL) of the fibre for a broadband range of wavelengths.

The PDL of a device-under-test (DUT) is the ratio of maximum transmitted power to minimum transmitted power with respect to all possible states of polarization at a given wavelength, expressed in dB. The details of how PDL is measured will not be discussed in this work therefore the reader is referred to (Hentschel C.), this work will only briefly explain what PDL is, and how it can be used to perform strain measurements. When an optical fibre is used as DUT, the PDL is expressed as:

$$\text{PDL}(\lambda) = \left| 10 \log_{10}(T_x(\lambda)/T_y(\lambda)) \right| \quad (4)$$

Where  $T_{x/y}$  represents the transmitted power along the x (y) polarization axis of the fibre.

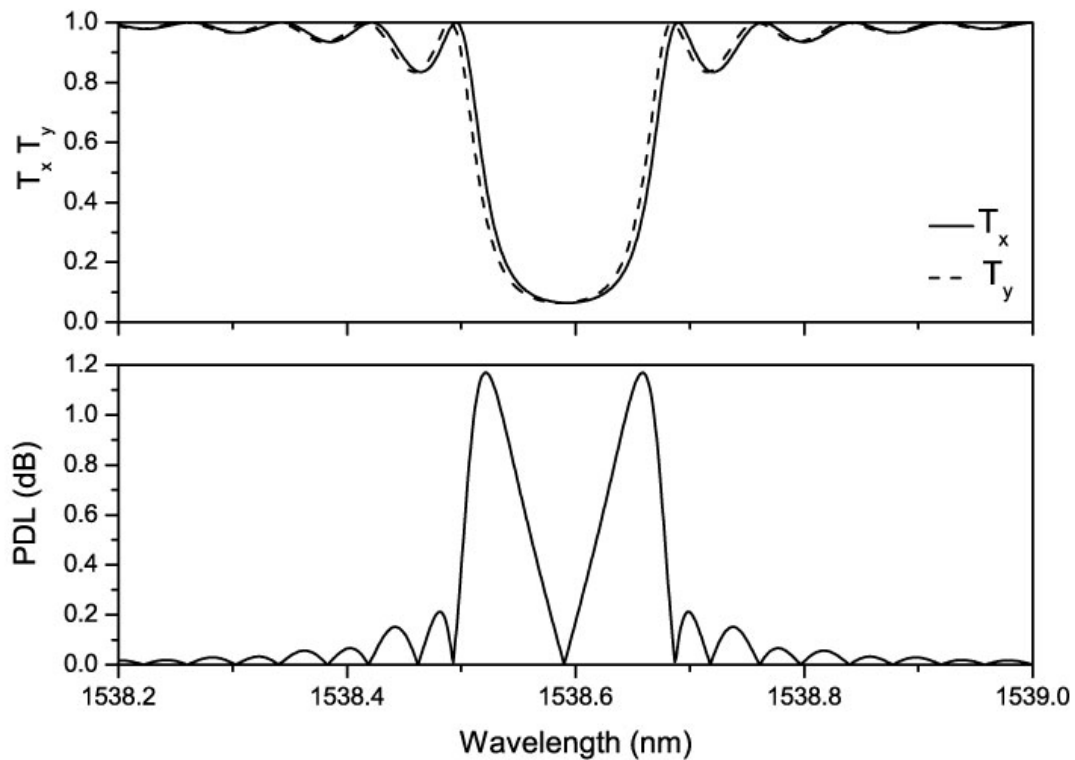

Figure 3: (top) simulated transmission spectra for both polarization axes; (bottom) PDL spectrum from the above-simulated spectra. (Caucheteur, Bette et al. 2009)

When the input wavelength  $\lambda$  is sufficiently different from the Bragg wavelengths defined by (2) – (3), the transmission  $T_x$  and  $T_y$  are nearly identical since they are unaffected by the presence of the grating. The PDL defined by (4) will then tend to zero. When the input wavelength  $\lambda$  approaches one of both Bragg wavelengths, the transmission along that polarization will be reduced strongly due to the grating. Equation (4) will then result in a PDL value tending to infinity. Finally, for a certain wavelength between both Bragg wavelengths, both transmission losses will be equal, leading to a zero value for the PDL. This leads to a double-peak PDL spectrum, which is illustrated in Figure 3. In Figure 3, the amplitude of the (total) transmitted light does not indicate the birefringence of the fibre, while it is clearly visible in the PDL spectrum.

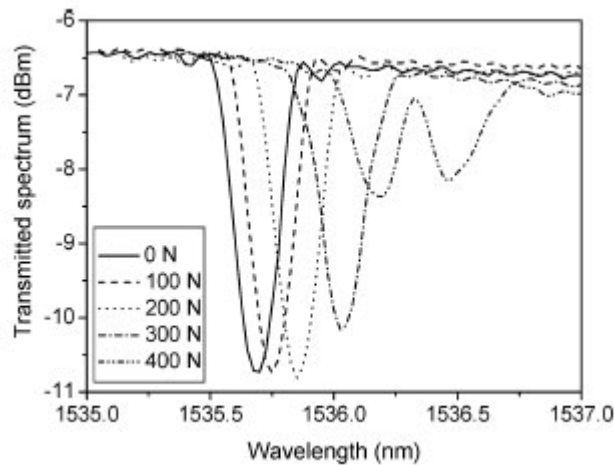

Figure 4: Amplitude transmission spectra during transverse loading (Caucheteur, Bette et al. 2007)

In (Caucheteur, Bette et al. 2007) it was shown that the PDL technique is capable of measuring transverse loads much sooner than is the case with traditional amplitude measurements. It is stated that in the performed experiments, peak separation only became visible in amplitude measurements at transverse loads of 300N and higher (Figure 4). By measuring the PDL peak power however, loads between 0N and 250N could be detected with a sensitivity of approximately 0.02 dB/N (Figure 5). At loads around 300N, the PDL power saturates as both peaks start to become fully separated and detectable in the amplitude measurements.

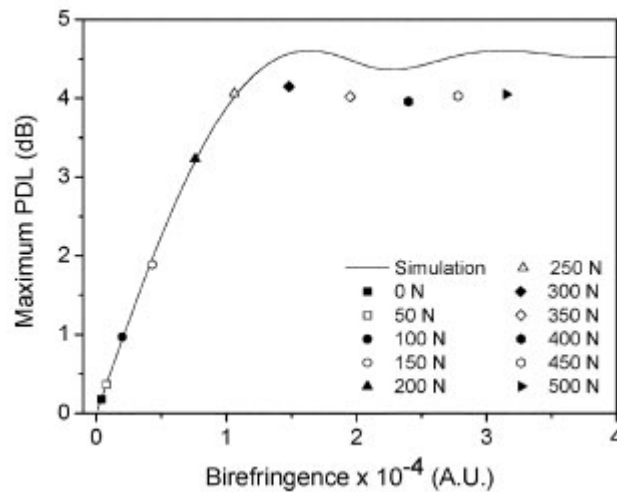

Figure 5: PDL peak power for different transverse loads (Caucheteur, Bette et al. 2007)

Out of these results, it is clear that PDL and traditional amplitude measurements can (and should) be used complementary. Amplitude measurements are well-suited for large transverse strain measurements or when peak separation is already present. PDL on the other hand is far superior in the measurement of small transversal strains such as during composite curing cycles.

## EXPERIMENTS

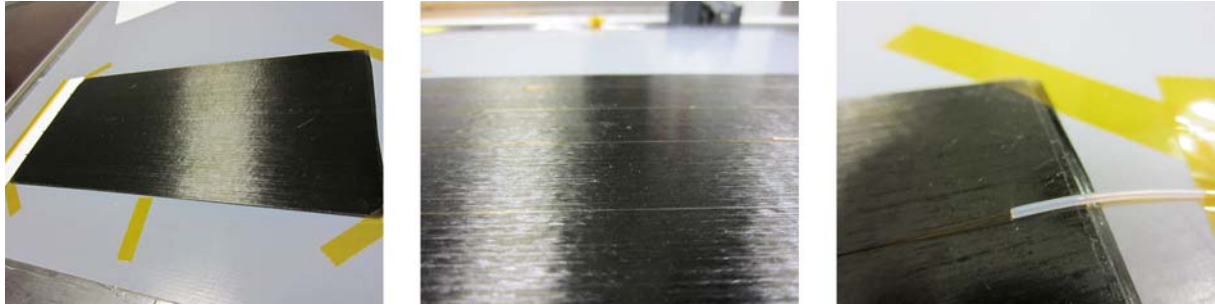

Figure 6: Embedding procedure of optical fibres in carbon fibre prepreg: (left) virgin carbon fibre prepreg cut to size (center) four optical fibres aligned to the reinforcement direction (right) fibre egress protected by Teflon tubing

In order to show the feasibility of the PDL technique towards transverse residual strain sensing, a set of carbon fiber reinforced polymer (M55J/M18) samples was created. The sample was 250mm x 125mm wide (Figure 6, left). This allows for 4 optical fibres (Figure 6, center) to be embedded, with spacing of 25mm between each fibre, and a margin of 12.5mm at each edge of the sample. Teflon tubing was placed over the fibres to protect the egress points (Figure 6, right). The lay-up was deliberately chosen to be a cross-ply laminate  $[0_2,90_2]_{2s}$  since strain can even be detected with

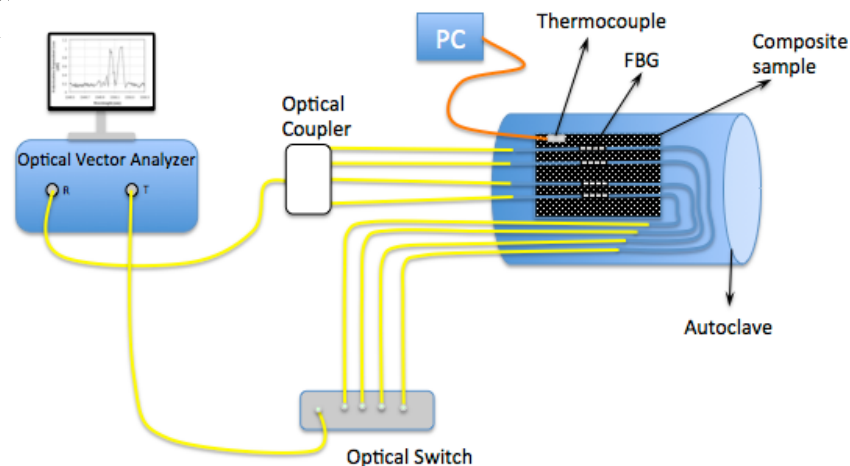

Figure 7: Schematical test set-up

The PDL measurements were performed using a LUNA Technologies Optical Vector Analyzer (OVA), allowing high accuracy PDL measurements (Figure 7). The laminates were cured in an out-of-autoclave fashion using vacuum bagging and a temperature cycle suited for the prepreg material. This approach simplifies the manufacturing cycle, since the autoclave does not need to be closed, thereby simplifying the optical fibre connections.

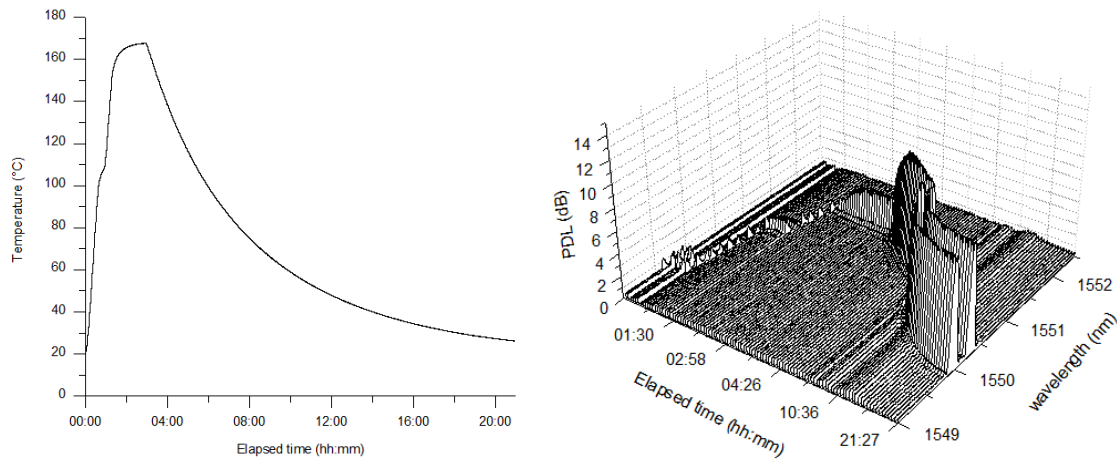

Figure 8: (left) Thermocouple measurements of temperature cycle, (right) PDL evolution during curing

The results from the experiments (Figure 8) clearly show the superior sensitivity of the PDL technique compared to normal interrogation schemes, when it comes to residual strain monitoring. In the PDL waterfall plot (Figure 8, right), it can be noticed that from the start two peaks are detected, for which the power evolves during cure, equivalent to residual-strain build-up. It can also be noticed that the peak PDL wavelengths separate during the curing, although this is a less sensitive measurement parameter than the PDL power. The average of both PDL peak wavelengths corresponds to the applied temperature cycle, as is to be expected from (2) and (3).

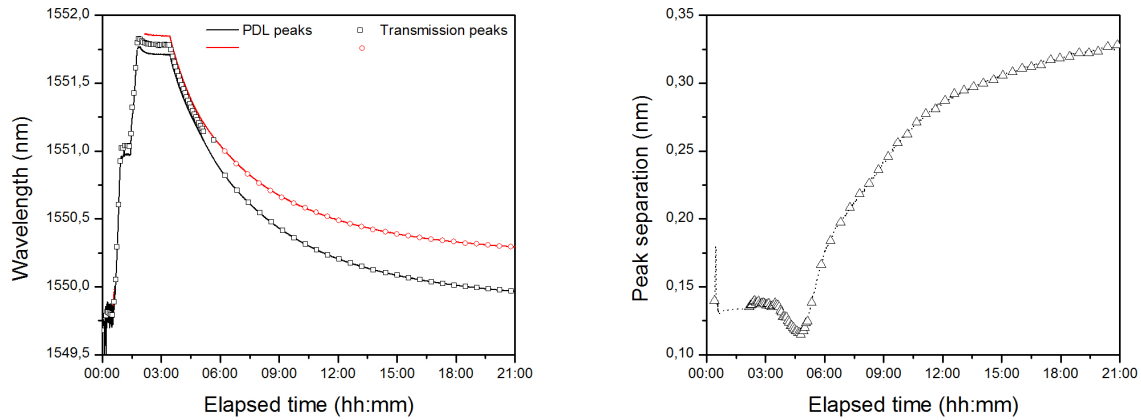

Figure 9: (left) Evolution of FBG peaks using PDL (full line) and amplitude measurements (dots). (right) Evolution of peak separation.

In Figure 9, the evolution of the FBG peaks is shown using the PDL technique (full lines), as well as using the default amplitude measurements (dots). It can be seen that, using amplitude measurements, it takes 6 hours before the peak splitting becomes detectable. Before that time, the amplitude measurement detects only a “fake” averaged peak value using a centre-of-gravity algorithm (Negri, Nied et al. 2011). The PDL on the other hand is capable much sooner of detecting peak separations. In Figure 9 (right), peak separation is clearly measurable using PDL during the plateau starting at about 3 hours. This can be further increased by tuning the parameters (noise threshold and minimum peak power) in the peak-detection algorithms.

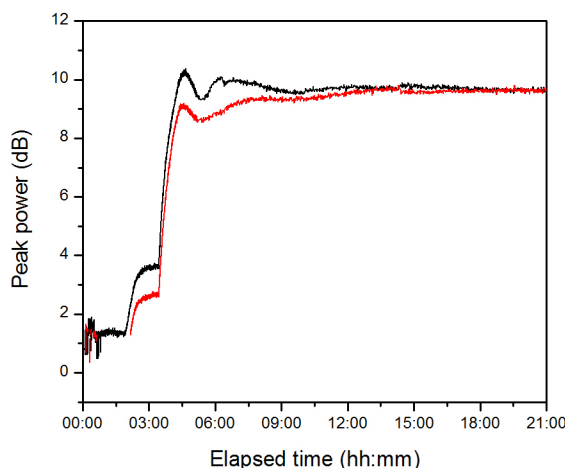

Figure 10: Evolution of PDL peak power during curing

Figure 10 shows the evolution of PDL peak power, which is the most sensitive parameter in a PDL measurement. Compared to PDL peak wavelength (Figure 9) where residual strains become clear after 3 hours of curing, PDL peak power reveals the existence of small residual strains after 2 hours of curing. The results in figure 10 also illustrate the possible saturation of the PDL peak power after approximately 8 hours of curing. While PDL peak power does not provide any additional information beyond this stage, peak separation has then become sufficient to be detected accurately using amplitude measurements (Figure 9).

## CONCLUSIONS

This work represents the first steps in the use of PDL towards residual strain monitoring of composite materials during production. It has illustrated the need for a more sophisticated interrogation scheme in order to accurately measure strains during production. Residual strain measurements on carbon fiber reinforced polymers show the superior resolution of PDL measurements over traditional amplitude measurements when small transverse strains have to be detected. The experiments show that PDL power saturates at higher transverse strains, at which point amplitude measurements are sufficiently accurate to detect birefringence. The current developments in PDL measurements only allow measurement rates in the range of 1Hz. It is therefore (currently) limited to static measurements such as cure monitoring or other slow processes.

## ACKNOWLEDGMENTS

The authors gratefully acknowledge the funding by the European Union within the FP7 – SmartFiber project. The authors acknowledge the European Regional Development Fund and the Wallonia (Mediatic project) as well as the Interuniversity Attraction Pole of the BelSPo photonics@be. C. Caucheteur is supported by the F.R.S.-FNRS.

## REFERENCES

- Caucheteur, C., S. Bette, et al. (2007). "Transverse strain measurements using the birefringence effect in fiber Bragg gratings." *Ieee Photonics Technology Letters* **19**(13-16): 966-968.

- Caucheteur, C., S. Bette, et al. (2009). "Influence of the Grating Parameters on the Polarization Properties of Fiber Bragg Gratings." Journal of Lightwave Technology **27**(5-8): 1000-1010.
- Chehura, E., C. C. Ye, et al. (2004). "Characterization of the response of fibre Bragg gratings fabricated in stress and geometrically induced high birefringence fibres to temperature and transverse load." Smart Materials & Structures **13**(4): 888-895.
- Henschel C., S. S. "PDL Measurements using the Agilent 8169A Polarization Controller."
- Luyckx, G. (2009). Multi-axial strain monitoring of fibre reinforced thermosetting plastics using embedded highly birefringent optical fibre Bragg sensors, Ghent University. Faculty of Engineering.
- Negri, L., A. Nied, et al. (2011). "Benchmark for Peak Detection Algorithms in Fiber Bragg Grating Interrogation and a New Neural Network for its Performance Improvement." Sensors **11**(4): 3466-3482.
- Voet, E. (2011). In-situ deformation monitoring of aerospace qualified composites with embedded improved draw tower fibre Bragg gratings, Ghent University. Faculty of Engineering and Architecture.
- Voet, E., G. Luyckx, et al. (2010). "Multi-axial strain transfer from laminated CFRP composites to embedded Bragg sensor: II. Experimental validation." Smart Materials & Structures **19**(10).